

Model RTH

Temperature & Humidity Recorders

Models RTH101A, RTH102A & RTH103A

- Temperature and/or humidity recording at low cost
- Simple installation & maintenance
- Uses proven bimetallic coil and hygroscopic membrane for reliable results

Introduction

The RTH100 Series of temperature and humidity circular chart recorders uses the proven design combination of bimetallic coils and hygroscopic membrane for the direct measurement of temperature and humidity.

Changes in atmospheric temperature and humidity are detected by the two elements within the recorder. The bimetallic coil monitoring the temperature and hygroscopic membrane monitoring the humidity.

Air is drawn through the instrument and over the two sensing elements by an electrically driven fan. Expansion or contraction of the bimetallic coil, due to temperature change, causes the pen movement by direct linkage. Similarly a change in humidity causes extension, or contraction, of the hygroscopic membrane and direct linkage again causes movement of the second pen.

Specifications

Range

Temperature: 0° to 40° or 20° to 100°F
 Humidity: 20 to 100% RH (see notes)

Measuring System

Temperature: Bi-metallic coil
 Humidity: Hygroscopic membrane

Accuracy

Temperature: ±1% of the chart range
 Humidity: ±2% within the limits 30 to 85% RH
 and 1° to 40°C

Chart

Diameter: 240 mm diameter

Drive: Electrical motor

24 hour or 7 day rotation as standard 3 hour, 6 hour, 12 hour and 28 day on application

Power Supplies

Voltage requirements: 110V or 230V 50/60 Hz
 Power requirements: <20VA
 Insulation, contact to earth: 2kV

Environmental Data

Storage temperature limits:

Temperature instruments: -10° to +50°C
 Temperature/humidity inst.: 0° to 40°C

Storage humidity limits

Temperature instruments: 0 to 90%RH
 Temperature/humidity inst.: 20 to 85% RH



Photograph shows control option that is no longer available

Casing

Glass filled resin case with lockable hinged door with perspex window (polycarbonate to special order)

Mounting

Ambient sampling Wall or flush panel or portable*
 Remote sampling Wall

Note

When panel mounting, a suitable air circulation must be provided to the duct intake and the inlet and outlet ports must not be restricted.

* Free standing portable version available (ambient sampling type only)

Weight

6.5 Kg approx.

Sampling Type

Total sampling line length is restricted to 1 metre max (20mm OD)

Note

Where the temperature difference between sample air and case exceeds ±5°C then the sample line must be thermally insulated

Note

Should the RH go above 85% RH it is possible that water droplets may form on the element. This may have a temporary or permanent affect on the calibration.

Ordering Information

- RTH temperature recorder
- RTH humidity recorder
- RTH temperature & humidity recorder

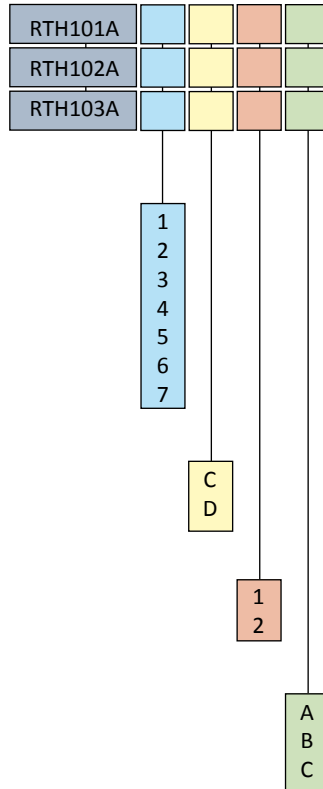

CHART ROTATION

- 3 hour
- 6 hour
- 12 hour
- 24 hour
- 7 day
- 28 day
- Multispeed

POWER SUPPLY

- Electric 110V 50Hz
- Electric 240V 50Hz

MOUNTING

- Wall / panel
- Portable

SAMPLING

- Ambient
- Remote
- Remote & Re-Entry

Dimensions & Fixings

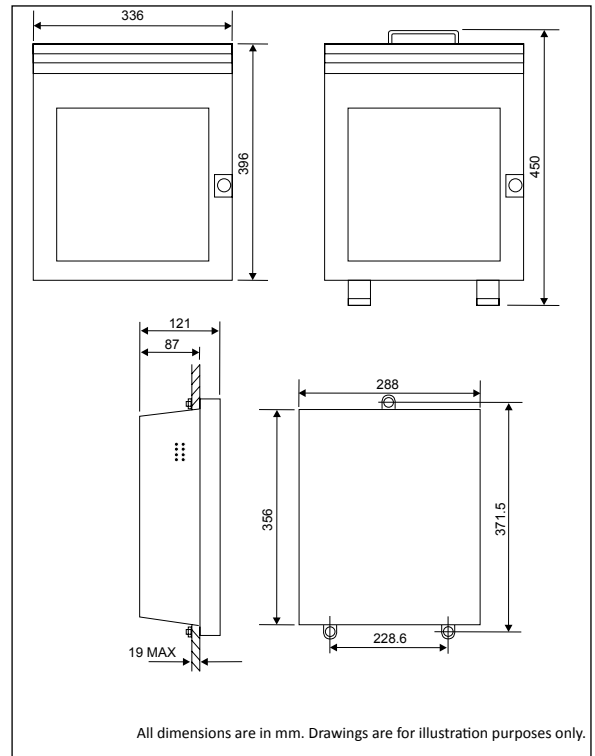

World-Wide Reliability & Quality

Rototherm's high quality and performance is guaranteed by an uncompromising approach to quality. British Rototherm's policy has always been to maintain a consistently high level of quality and reliability throughout its product range and service to customers.



The company has worked energetically towards establishing comprehensive quality controls and has earned a worldwide reputation for product quality.



British Rototherm Company Limited

Kenfig Industrial Estate, Margam, Port Talbot SA13 2PW United Kingdom
 Telephone : +44 (0) 1656 740 551 Facsimile : +44 (0) 1656 745 915

E-mail : sales@rototherm.co.uk sales@thermocouple.co.uk
 Web Site : www.rototherm.co.uk www.thermocouple.co.uk

