

Chart Recorder Product Catalogue



Microprocessor Based Chart Recorders | Mechanical Chart Recorders | Pneumatic Controllers
Temperature | Pressure | Humidity | Flow



Welcome to British Rototherm

With over seventy years of experience, the British Rototherm Group continues to be a world leader in the manufacture of industrial instrumentation for measuring, monitoring and controlling Temperature, Pressure, Humidity and Flow.

British Rototherm and Thermocouple Instruments products are manufactured in a modern factory located in the South Wales region of the United Kingdom. Sited on 6 acres of land at Kenfig Industrial Estate, the company operates from a modern 6,030 square metre (65,000 square feet) factory.

British Rototherm is an established manufacturer of custom designed process measurement equipment for a wide range of industries including Petrochemical, Oil and Gas, Chemical, Contract Engineering, Pharmaceutical, Food and Brewing, Defence, Power, Steel and Water.

We pride ourselves on our strength and versatility, expressed by our ability to design and manufacture to your exact requirements. This is really where our in-house expertise excels and can tailor the exact solutions to your needs.

Our Mission

It is our philosophy that the customer is the absolute priority. We have a duty to maintain this principle, and we believe it will give us the edge over our competitors.

We have a highly trained team of sales engineers who listen to, and understand your needs, to achieve the very best solutions with the minimum of fuss. Our drawing office is extremely experienced and can provide detailed drawings of your requirements prior to manufacture. Customer satisfaction and approval, particularly at these early stages, means everything. From planning, through manufacture, assembly and testing our quality management systems ensures your expectations are exceeded.

Our Group

Over the past 15 years, the Rototherm Group has been expanded to include a number of well know companies, each well established as market leaders within their business.

At the centre of each group member is the continued commitment to product quality and the highest levels of customer service.

Thermocouple Instruments

A world leader in the manufacture of temperature assemblies and flow instrumentation.

For more information visit: www.thermocouple.co.uk

RTD Products

The UK's leading manufacturer of ceramic encapsulated wire wound platinum resistance temperature detectors.

For more information visit: www.rtd-products.co.uk

Bentley Instruments Co. Ltd.

Ireland's leading provider of solutions in the fields of instrumentation, on-site calibration and service, metal detection, tablet and capsule de-dusting and powder handling.

For more information visit: www.bentley-instruments.com



www.rototherm.co.uk - an essential source of information for all Rototherm Group products and services



Quality First

At the centre of everything we do, Rototherm's high quality and performance is guaranteed by an uncompromising approach to quality. Our quality process is crucial to our service and our ISO9001 and ATEX approved assemblies ensure you get quality service not only from the product, but also from the moment you call us.

Rototherm's policy has always been to maintain a consistently high level of quality and reliability throughout its product range and service to customers.

The company has worked energetically towards establishing comprehensive quality controls and has earned a worldwide reputation for product quality.

All calibration standards are traceable to national standards thus allowing the issuing of test or calibration certificates when required.



ISO9001:2000
FM11958



Worldwide Reliability

British Rototherm has worked hard to develop a network of distributors and stockists throughout the United Kingdom and the rest of the world who can be relied upon for support, technical advice and service.

Rototherm's main distributors and stockists are located in the following countries:

- Australia
- Abu Dhabi
- Bahrain
- Brunei Darussalam
- Canada
- Chile
- Dubai
- Egypt
- Greece
- Hong Kong
- India
- Indonesia
- Iran
- Ireland
- Italy
- Kenya
- Kuwait
- Malaysia
- The Netherlands
- New Zealand
- Nigeria
- Norway
- Oman
- Pakistan
- Qatar
- Saudi Arabia
- Singapore
- South Africa
- Spain
- Taiwan
- Thailand
- United States of America
- Vietnam

Product Capabilities

This catalogue features just a small part of the British Rototherm range of products. A comprehensive range of catalogues is available featuring our other product groups including Temperature Assemblies, Flow Products and Pressure Gauges. These catalogues can be requested from British Rototherm or downloaded from www.rototherm.co.uk/datasheets.htm



Contents

Welcome to British Rototherm	1
Chart Recorders & Recorder Controllers Overview	4
Chart Recorders & Recorder Controllers	
Sentinel Programmable Microprocessor Based Recorder Controllers	5
Clearscan Temperature, Pressure & Flow Recorders	8
Clearscan C105 & M105 Pressure & Temperature Recorders	13
RPO & RTO Pressure & Temperature Recorders	17
RTH Temperature & Humidity Recorders	21
Controllers & Recorder Controllers	
Pneumatic Recorder Controller Options	23
IP600 & IT600 Indicating Pneumatic Controller	24
Clearway M140 Indicating Pneumatic Controller	25
Other Products Available	
Thermometers Overview	27
Pressure Gauges Overview	28
Temperature Assemblies Overview	29
Flow Products Overview	30

Chart Recorders & Recorder Controllers Overview

- Temperature, Pressure, Flow & Humidity
- Rugged design & construction
- Accurate & reliable measuring systems
- Up to 3 recording pens
- Simple installation & maintenance required

- Fully mechanical versions available
- Choice of mounting options - wall / panel / portable / pipe
- Electrical control options
- Pneumatic control options
- Spares and consumables widely available

An extensive range of chart recorders and controllers which includes programmable microprocessor electric-input recorder controllers and a wide range of mechanical recorders for temperature, pressure, humidity and flow with options for electrical or pneumatic control.

Rototherm chart recorders can be used to record and control:

- Temperature
- Pressure
- Humidity
- Flow

Each recorder is supplied with a packet of 100 charts and 1 spare packet of pens for each pen specified. Consumable items and spare parts are readily available from British Rototherm

Clearscan Chart Recorders

The Clearscan range of recorders is suitable for most industrial applications and can be fitted with up to 3 pens for recording temperature, pressure and flow.

Sentinel Micro-processor based chart recorders

The Sentinel range of micro-processor based circular chart recorders is available in 1, 2 and 3 channel versions. Sentinel combines the simplicity and clarity of pen drawn traces together with the versatility of microprocessor control.

RTO Series Temperature Chart Recorders

The filled system range of temperature circular chart recorders uses the well proven and reliable Rototherm stainless steel thermal system.

Up to three pens can be fitted with three temperature systems or a combination of temperature, pressure or flow sensing systems.



Sentinel Recorders



Clearscan Recorders



C105 Recorders



M105 Recorders



RPO / RTO Recorders



RTH Recorders

RPO Series Pressure Chart Recorders

The RPO series of pressure circular chart recorders uses the well proven and reliable Rototherm non ferrous or stainless steel pressure system. Up to three pens can be fitted with three pressure systems or combination of temperature, pressure or flow sensing systems.

Clearscan C105/M105 Pressure & Temperature Chart Recorders

Developed from the ex Kent Industrial Measurement and Cambridge range of circular chart recorders, the round case C105 and rectangular cased M105, continue to be available and still offer the same reliability and versatility that has been manufactured for the past 30 years.

Chart Recorders - features

	Maximum number of pens	Chart Diameter	Wall Mounting	Portable Mounting	2" pipe mounting	Electric chart drive	Mechanical chart drive	All mechanical version	Temperature / Pressure	Temperature / Humidity	Electrical Input	Electrical Control	Pneumatic Control	Flow version	Timber Kiln version	Dairy version
Sentinel Microprocessor Recorders	3	9"	●	○	⊗	●	⊗	⊗	○	○	●	●	⊗	○	○	○
Clearscan Recorders	3	12"	●	○	○	○	●	○	○	⊗	⊗	⊗	⊗	○	⊗	⊗
C105 Recorders	2	10"	●	○	○	●	○	○	○	⊗	⊗	⊗	⊗	⊗	⊗	⊗
M105 Recorders	2	10"	●	⊗	⊗	●	○	○	○	⊗	⊗	○	○	⊗	○	⊗
RPO Pressure Recorders	3	9"	●	○	○	●	○	○	○	⊗	⊗	○	○	⊗	⊗	⊗
RTO Temperature Recorders	3	9"	●	○	○	●	○	○	○	⊗	⊗	○	○	⊗	⊗	⊗
RTH Series Recorders	2	9"	●	○	⊗	●	⊗	⊗	⊗	○	⊗	⊗	⊗	⊗	⊗	⊗

● = standard ○ = option ⊗ = not available

please refer to product pages in this catalogue for full product specifications

Sentinel Programmable Microprocessor Based Recorder Controllers

The Sentinel range of microprocessor-based circular chart recorders is available in 1, 2 or 3 channel variants.

Sentinel combines the simplicity and clarity of pen drawn traces together with the versatility of microprocessor control.

Each channel is equipped with a universal signal input which is compatible with all industry standard sensors and signals including thermocouple types J, K, T, E, N, R, S and B, Pt100 platinum resistance temperature detectors and 4/20mA current loops.

Low and high measurement ranges are provided for each input type, separate range cards are not required. Multi input versions include optoelectronic isolation of the input stages to eliminate troublesome installation ground loops.

Thermocouple and RTD characteristics are fully linearised by means of software. In addition thermocouple measurements benefit from automatic cold junction compensation which uses software correction in conjunction with a stable platinum resistance detector for cold-junction temperature sensing.

Alarm relay facilities are comprehensive. Single pen recorders are equipped with three failsafe single-pole changeover relays, six relays are standard on the two and three pen versions. Colour-coded light-emitting diodes show the status of each relay at a glance. All relay functions are under software control: set point values and hysteresis levels are entered directly via the keypad, relay action and channel assignment are selected from user friendly menus. Relays may be freely assigned to any recording channel.

The rotation speed of the 240mm diameter chart is microprocessor controlled and user programmable. Linear Sentinel charts are compatible with other recorders in the Rototherm range.

All Sentinel recorders are housed in a strong steel case with a moulded door that can be panel or surface mounted. A gasketed lockable door protects internal components from harsh industrial environments and offers protection generally to IP55. A tough acrylic window allows the chart trace, digital channel readings and alarm status to be viewed with the recorder's door closed.

Simple to setup, simple to operate

Ease-of-operation is an important feature of all Sentinel recorders. The operator's panel includes a five position tactile keypad and a two-line backlit liquid crystal display with large easy-to-read characters. Using this straightforward interface the Sentinel is quickly configured to suit each application.

Clear prompts and menus presented on the large character display guide the operator through the setup procedure with confidence.

The input type, chart range, display units, chart speed and relay configurations are selected from logically- ordered option menus.

At each stage of the setup procedure the display recalls the value or setting currently stored in memory and data entries are checked automatically. The keypad allows direct entry of numerical values such as relay set points and measurement ranges.

The time for a chart revolution may be set between 1 hour and 31 days in steps of 1 hour or 1 day. To ease chart changing a motorised pen lifter parks the pens at the edge of the paper.



Sentinel's high speed chart advance / reverse facility allows the chart to be set quickly to the correct time mark.

Three levels of security, including password and hardware protection are available to stop unauthorised access and alteration of the recorder's configuration. All configured data (type of input, chart range, chart speed, display units, set points, etc.) are stored in non-volatile memory for security in the event of power failure.

Simple to install and maintain

A choice of mounting options enables simple installation in a panel or surface mounting on a wall. The Sentinel recorder case is compatible with the standard Rototherm recorder panel cut-out.

Sentinel's circuits with excellent long term stability maintain performance and keep recalibration to a minimum, cutting the costs of maintenance.

Internal Layout of Sentinel - Chart Plate

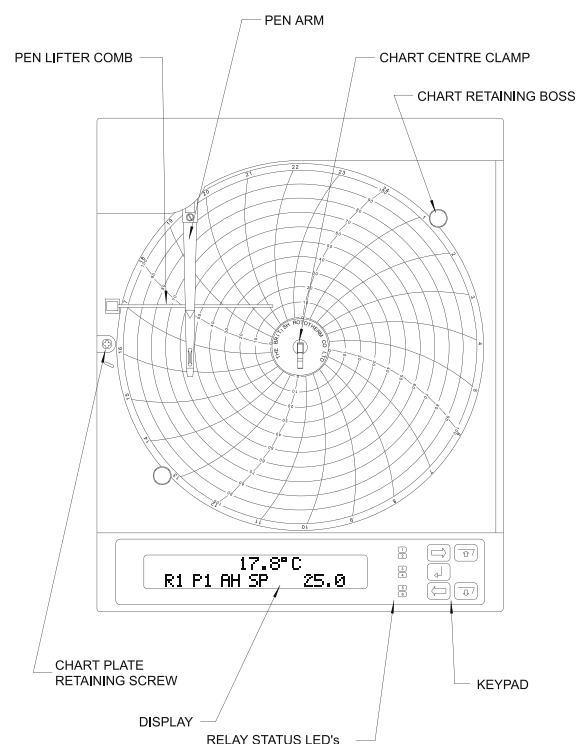

Sentinel Models

SEN10	Single pen recorder controller
SEN20	Two pen recorder controller
SEN30	Three pen recorder controller
SEN10F	Single pen recorder controller - Flow version
SEN20F	Two pen recorder controller - Flow version
SEN30F	Three pen recorder controller - Flow version
SEN30P	Three pen recorder controller - Dairy version
SEN20KD	Two pen recorder controller - Timber Kiln version

Specifications

INPUTS

Number: 1, 2 or 3
Input Signals: (Standard) Thermocouples K, T, J, N, E, B, R & S
 Platinum RTD (Pt100) 3-wire
 DC voltage $\pm 2V$, +20V
 DC current $\pm 2mA$, $\pm 20mA$

Temperature Ranges:

Thermocouples to BS4937 (type B minimum temp 200°C) RTD to BS1904:1984
 High and low measurement ranges for each input

Cold-Junction Compensation:

Automatic, using Pt1000 temperature detector and software correction

Linearisation: Automatic software linearisation to BS4937 (thermocouples) and BS1904: 1984 (RTD)

Input Resistance: T/C: 10 Mohms
 $\pm 2mA$: 200 ohms
 $\pm 20mA$: 20 ohms
 $\pm 2V$, +20V: >1 Mohms

Minimum Span: 5°C (Thermocouples K, J, T, E, N & RTD)

Thermocouple Burn-out:

Pull-up or pull-down, link selectable

RTD Current: 1mA approximately

RTD Lead Resistance:

3-lead connection, compensated up to 10 ohms maximum per lead

Input Protection: $\pm 50Vdc$ on signal inputs

Input Isolation: Optoelectronic on 2 and 3 input versions
 500Vrms channel-to-channel, 500Vrms channel-to-earth

PERFORMANCE

Accuracy: RTD: Low range (<200°C) $\pm 0.2^\circ C$,
 High range (>200°C) $\pm 0.8^\circ C$ (Ambient 20°C)
 T/C: $\pm 0.25\%$ FS
 Linear: $\pm 0.2\%$ FS

Temperature Stability:

$\pm 0.02\%$ FS/ $^\circ C$

Cold Junction Compensation Stability:

$\pm 0.02^\circ C/^\circ C$

Linearisation Accuracy:

Thermocouple Types J, K, T, N, E : $\pm 0.1^\circ C$ - 50/200°C, $\pm 1^\circ C$ max
 Thermocouple Types R & S : $\pm 0.2^\circ C$ - 50/200°C, $\pm 1^\circ C$ max
 Thermocouple Type B : $\pm 1^\circ C$ max.
 RTD :Pt100 Better than $\pm 0.1^\circ C$ - 200/850°C

Calibration Shift: $\pm 10^\circ C$ user programmable to eliminate sensor errors (T/C & RTD)

A to D Converter: Integrating, 16-bit resolution with 50/60Hz noise rejection

Conversion Rate: 2 per second

Noise Rejection: >120dB common-mode, 60dB normal mode
 50/60Hz

CHART & DISPLAY

Chart Size: 240mm (9.5") circular paper chart

Chart Divisions: 40, 50, 60, 70 or 80 linear divisions

Chart Drive: DC stepper motor

Chart Speeds: 1 to 24 hours in steps of one hour, 2 to 31 days in steps of 1 day

Writing Method: Disposable ink cartridges. Pen 1 Red, Pen 2 Green, Pen 3 Blue

Pen Positioner: DC stepper motor

Positioning Resolution:

Better than 0.1% of full-scale

Pen Response Time:

Zero to full-scale in 4.5 seconds

Pen Lift: Motorised, activated from front panel. Chart fast time advance possible with pens raised.

Display Type: 2 line x 20 character dot matrix liquid crystal with backlight and automatic temperature compensation. Character height 9.6mm.

Display Resolution:

Temperature ranges 0.1°C, linear ranges software programmable

Alarm Display: Relay status shown by red and green front panel LEDs

RELAYS

Number: 3 on single pen, 6 on two and three-pen versions.

Relay Actions: Software selectable from:-
 High alarm/Low alarm/Deviation alarm/Control relay (high)/Control relay (low). Relays de-energise in alarm state

Assignment: Relays freely assignable to any channel

Hysteresis Level: User programmable 0.0% to 10% of span

Relay Contacts: SPCO silver alloy

Switched Load: 150W dc, 1660VA ac non-inductive

Switched Current: 6A max

Switched Voltage: 30Vdc, 250Vac

Snubber Network: 22nF +100R

GENERAL

Security: 3-level software lock including password protection, internal hardware jumper lock, lockable door.

Power Supply: 115V or 230Vac $\pm 10\%$, switch selectable, 50/60Hz.

Power Requirements:

<25W

Operating Temperature:

0 to 55°C

Operating Humidity:

0 to 90% RH (non condensing)

Case: Steel case with acrylic door window

Protection: IP55

Mounting: Panel or surface

Weight: 7kg (single pen) 7.7kg (three pen)

Dimensions (overall):

336 x 396 x 171 mm (w x h x d)

Panel Cut-out: 288 x 356 mm (w x h)

Specifications continued

OPTIONS

Retransmission

Output Current: 0 to 20mA or 4 to 20mA.

Resolution: 12 bits (0.024%)

Output Compliance:

20V approx.

Isolation: Optoelectronic

Assignment: Card assignable to any channel. Retransmission range software selectable anywhere within chart range

Action: Direct or reverse

Event pen

Number of Inputs: Two

Pen Positions: Four, 0, 33, 66, 100% of pen sweep

Sweep: Position on chart user configured, forward or reverse.

Input Voltage: 48-250Vac (card CR0027-E)
5-24Vdc (card CR0031-E)

Transmitter PSU

Input: Isolated output, voltage 12/24V link selectable

Dimensions & Fixing

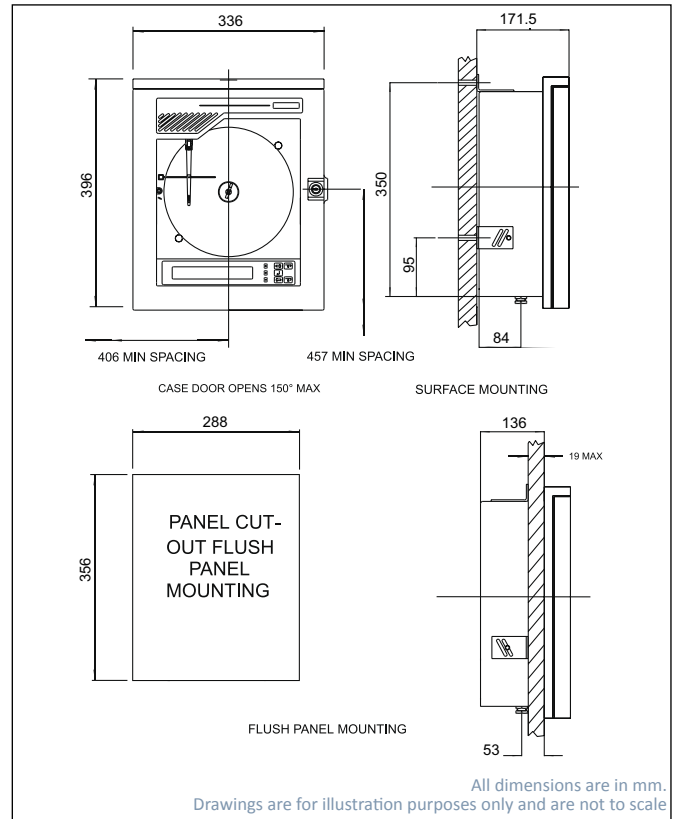

Order Codes

Sentinel Recorder Controller - single pen

Sentinel Recorder Controller - two pen

Sentinel Recorder Controller - three pen

Sentinel Recorder Controller - single pen - flow version

Sentinel Recorder Controller - two pen - flow version

Sentinel Recorder Controller - three pen - flow version

Sentinel Recorder Controller - three pen - dairy version

Sentinel Recorder Controller - two pen - timber kiln version

Alarms (user configurable)

3 alarms (standard on single pen)

6 alarms (standard on 2 and 3 pens, option for single pen recorder)

Retransmission

Required

Not required

Events Pen

Required (1 pen only)

Not required

Transmitter Power Supply

Required

Not required

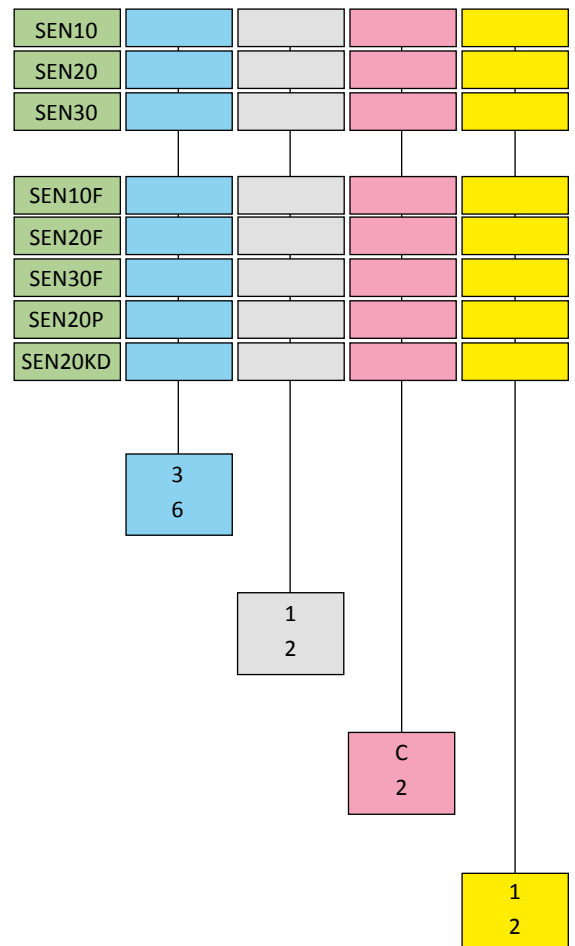

Clearscan Temperature, Pressure & Flow Recorders

- 1, 2 or 3 pen temperature, pressure & flow recording
- Uses proven and reliable Rotothem temperature, pressure and differential pressure systems
- Simple installation and maintenance requirements
- Wall, panel, portable or pipe mounting available
- Fully mechanical versions available
- Electrical, battery or mechanical chart drive options
- Large 12 inch diameter chart
- Large choice of temperature, pressure and differential pressure ranges

General Description

Case

The Clearscan recorder case is made from high quality zinc coated steel, finished in epoxy powder paint that has a high resistance to weathering, scratches and industrial fumes. The window is high quality acrylic. The case has a lockable front-hinged door, permitting easy access to the chart and pens, and may be either wall, panel or pipe mounted.

Pens

The Clearscan recorders utilise sealed ink capsules with built-in fibre tipped pens which are simple to replace and without any mess. Single pen recorders and the first pen of two and three pen recorders trace in red ink; the second pen of two pen and three pen recorders traces in blue and the third pen of three pen recorders in green. Each recorder is supplied with a spare packet of pens.

Charts

Clearscan Chart Recorders use a 12 inch circular charts which are interchangeable with Barton, Graphic Controls and Bristol charts. The standard chart durations are one revolution every 24 hours or 7 days - other rotations are available. A pen lift is fitted to ease chart changing. Each recorder is supplied with a packet of 100 charts.

Chart Drive Motor

The Clearscan Chart Recorder uses chart drive motors that are available as mains powered, mains powered with battery back-up, mechanical (spring-wound) and battery operated with a wide variety of chart speeds (24 hour and 7 day are standard).

Temperature Systems

The Clearscan chart recorder uses the proven and reliable Rotothem stainless steel thermal system. These consist of a bourdon tube, stainless steel capillary and a stainless steel bulb. All systems are filled with a non toxic filling temperature systems.

Pressure Systems

Proven and reliable pressure systems are used to record gauge pressure, vacuum, combined pressure and vacuum, absolute pressure and differential pressure.

Differential Pressure Systems

Differential pressure and flow can be recorded by using a differential pressure cell mounted to the rear of the instrument.

Minimum differential pressure range is 0 to 100" Wg.

Wetted parts can be supplied in a variety of materials to suit a broad range of process applications.



Image shows red and green pens. Second pen is now blue

Clearscan Models

Temperature Recorders

CST100	Single Pen Temperature Recorder
CST200	Two Pen Temperature Recorder
CST300	Three Pen Temperature Recorder

Pressure Recorders

CSP100	Single Pen Pressure Recorder
CSP200	Two Pen Pressure Recorder
CSP300	Three Pen Pressure Recorder

Combined Temperature & Pressure Recorders

CSTP200	Two Pen Temperature & Pressure Recorder
CSTP300	Three Pen Temperature & Pressure Recorder

Flow (Differential Pressure) Recorders

CSF100	Single Pen Flow Recorder
--------	--------------------------

Combined Flow & Temperature Recorders

CSFT200	Two Pen Flow & Temperature Recorder
CSFT300	Three Pen Flow & Temperature Recorder

Combined Flow & Pressure Recorder

CSFP200	Two Pen Flow & Pressure Recorder
CSFP300	Three Pen Flow & Pressure Recorder

Combined Flow, Temperature & Pressure Recorder

CSFTP300	Three Pen Flow, Temperature & Pressure Recorder
----------	---

Specifications

Accuracy

+/-1% FSD

Ambient Temperature

-20°C to +50°C

TEMPERATURE SYSTEM

Measuring Element

Rototherm thermal bourdon tube temperature compensated.

Capillary

Microbore stainless steel tube with 3mm diameter stainless steel cover (type C1) as standard.

Other capillary types are available.

Bulb and Stem

Stainless steel BS970 316. Standard diameter is 12.7mm.

Fittings

Compression gland (adjustable). Stainless steel (1/2" BSP is standard). Other BSP, NPT and API are available on request. (suitable for pressures up to 3.5 bar)

PRESSURE SYSTEM

Measuring Element

Bourdon Tube, Helical Coil or pressure capsule, in non ferrous or stainless steel material as applicable. Monel to NACE standards is offered as an option.

DIFFERENTIAL PRESSURE SYSTEM

Measuring Element

Rototherm Differential Pressure Unit in 316 stainless steel. Elements in alternative materials to NACE standards are also available.

Chart Drive Motor

Synchronous electric, battery or mechanical spring wound. 24 hour or 7 day & dual speed rotation. (other rotations on request)

Charts

Disc 300mm (12 inches) diameter.

Standard dividing 40, 50, 60, 70 or 80 linear divisions.

Interchangeable with Barton, Graphic Controls and Bristol charts.

Inking System

Disposable fibre tipped pens.

1 pen : red.

2 pen : red & blue.

3 pen : red, blue and green.

Case

High quality steel finished in 2 pack epoxy powder paint that has a high resistance to weathering, scratches and industrial fumes. The case has a lockable front-hinged door.

Window

Acrylic

Power Supply

200 to 250 volts, 50Hz (60Hz available); 100 to 110 volts, 50Hz (60Hz available)

Battery operated chart drives require 1.5 volt type "AA" cell.

Mounting

Suitable for surface or panel mounting. (Pipe mounting & Portable options are available)

Weight (approx)

Single pen : 9.5 kg (21 lb)

Two pen : 10.0 kg (22 lb)

Three pen : 10.5 kg (23 lb)

The above weights include 3 metres of capillary.

For each additional 3 metres add 0.25kg (0.5lb)

Bulb Types

Type 301

This bulb type is used when no compression fitting is required. This bulb may be held in place by a bracket or clip (not supplied by Rototherm) or may be inserted directly into the process.

Type 302

This bulb has a compression gland fitting that slides along the capillary and is tightened into the required position. This bulb type is only available with plain stainless steel capillary (type C1) - armoured capillaries are not available as it is not possible to move the fitting along the armoured capillary. Bulb length cannot be specified.

Type 303

Compression gland fittings tighten on the bulb to provide liquid and gas tight seal. Once fitted the position of the gland fitting can only be altered by cutting off the olive and replacing it with a new one.

If required this bulb type may be specified with a compression gland fitting - in this instance please confirm the required overall length of the bulb.

Type 301

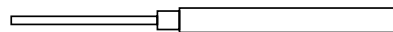

Type 302

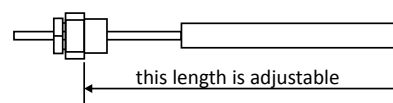

Type 303

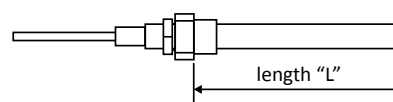

Dimensions

Dimensions for Clearscan chart recorder - wall or panel mounting

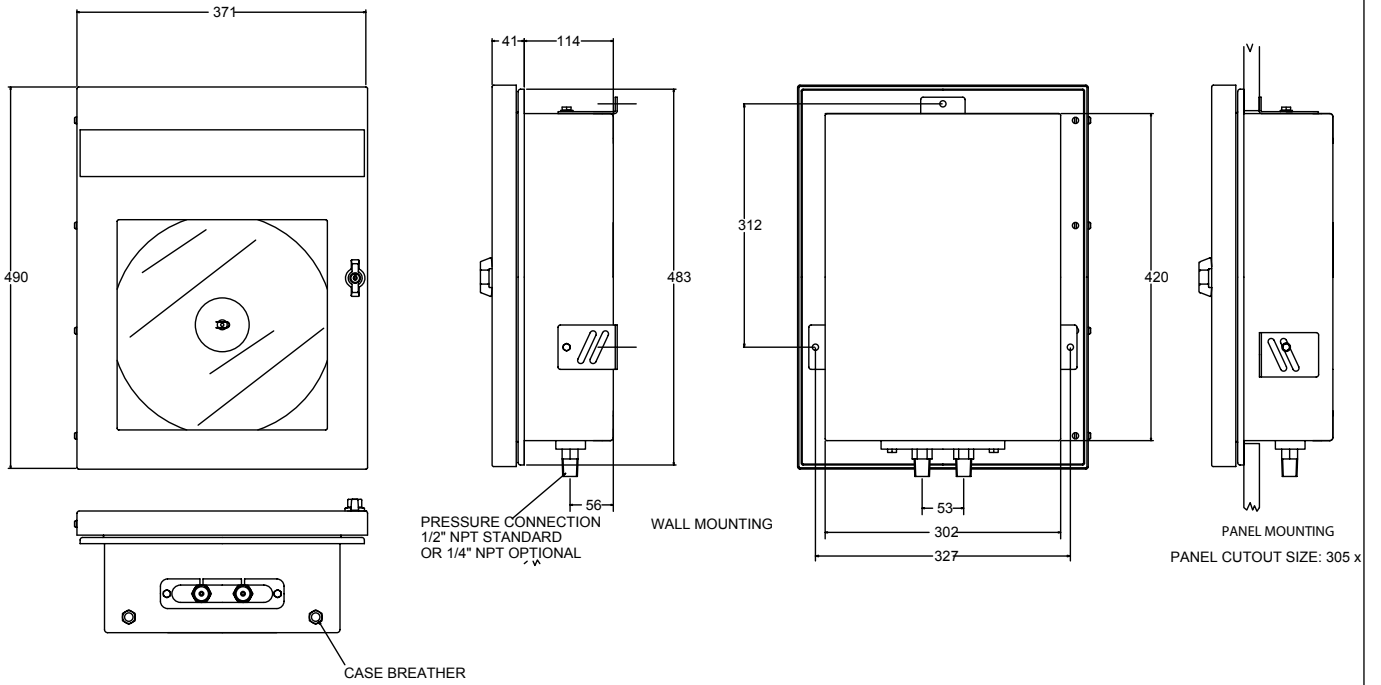

Dimensions for Clearscan chart recorder - 2" pipe / post mounting

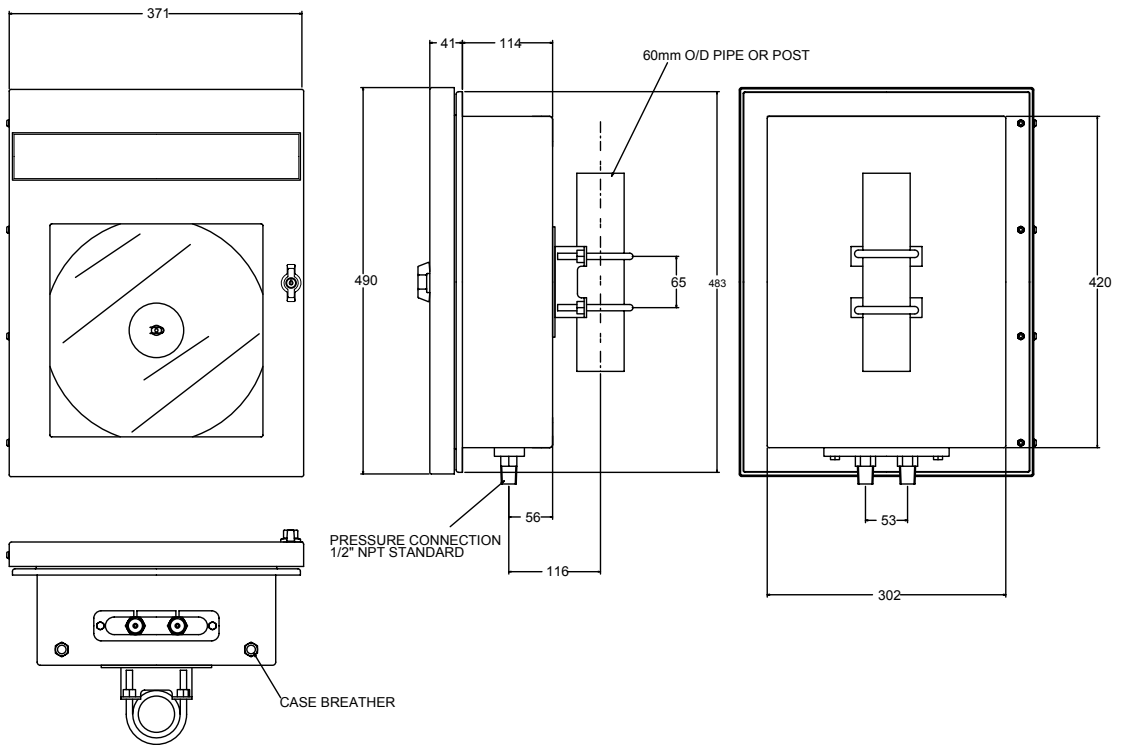

All dimensions are in mm.
Drawings are for illustration purposes only and are not to scale

Standard Temperature Ranges

Range	Range
-40 to +40 Deg C	0 to 160 Deg C
-30 to +30 Deg C	0 to 200 Deg C
-30 to +50 Deg C	0 to 300 Deg C
-25 to +25 Deg C	0 to 400 Deg C
0 to 40 Deg C	20 to 120 Deg C
0 to 50 Deg C	50 to 150 Deg C
0 to 60 Deg C	50 to 250 Deg C
0 to 100 Deg C	100 to 400 Deg C
0 to 120 Deg C	100 to 500 Deg C

Calibration in other units of pressure and temperature as well as non-standard ranges are available on request

Standard Pressure Ranges

Standard Range	Sensing Element	Material
0 to 2.5 bar 0 to 4 bar 0 to 6 bar 0 to 10 bar 0 to 16 bar 0 to 25 bar 0 to 40 bar 0 to 60 bar 0 to 100 bar 0 to 160 bar 0 to 250 bar 0 to 300 bar 0 to 400 bar 0 to 600 bar 0 to 1000 bar 0 to 1200 bar 0 to 1600 bar	Bourdon Tube	Stainless Steel or Monel to NACE

Ordering Codes - Basic Recorder - Mounting & Chart Drive - see page 28 for measuring system(s) ordering information

- Single Pen Temperature Recorder
- Two Pen Temperature Recorder
- Three Pen Temperature Recorder
- Single Pen Pressure Recorder
- Two Pen Pressure Recorder
- Three Pen Pressure Recorder
- Two Pen Temperature & Pressure Recorder
- Three Pen Temperature & Pressure Recorder
- Two Pen Flow & Temperature Recorder
- Two Pen Flow & Pressure Recorder
- Three Pen Flow & Temperature Recorder
- Three Pen Flow, Temperature & Pressure Recorder

Mounting

- Wall / Panel
- Portable
- 2" Pipe / Post

Chart Drive

- Electric 240V 50Hz
- Electric 110V 50Hz
- Mechanical Spring Wound
- Battery Operated
- Electric 240V 50Hz with Battery Backup
- Other*

Chart Rotation

- 24 hour
- 7 day
- Dual speed 24 hour / 7 day
- Other*

*please state requirement

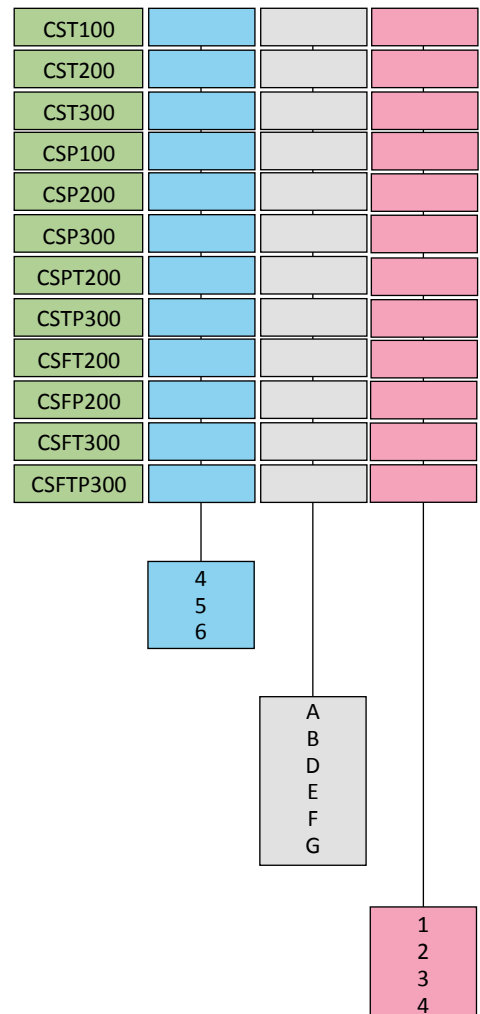

Ordering Codes - Recorders fitted with Temperature Systems

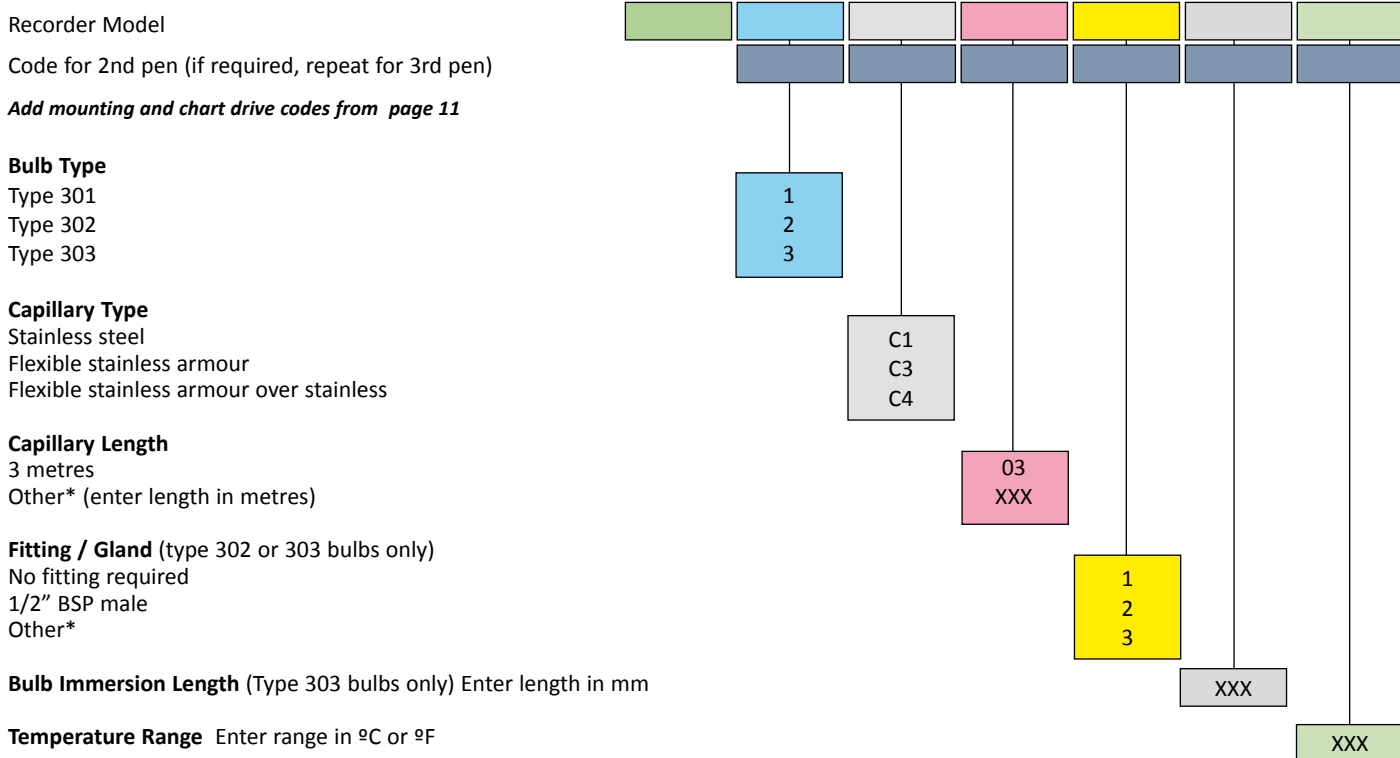

Ordering Codes - Recorders fitted with Pressure Systems

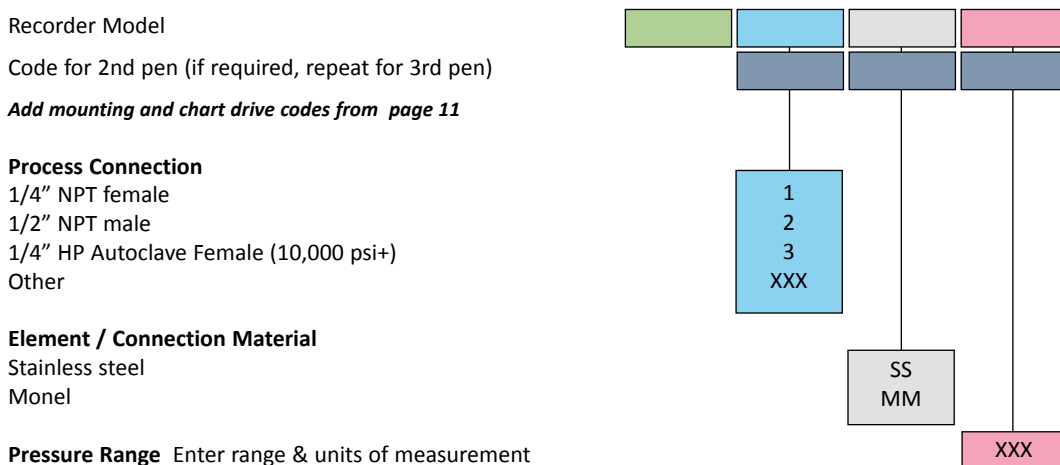

Ordering Codes - Recorders fitted with Differential Pressure Systems

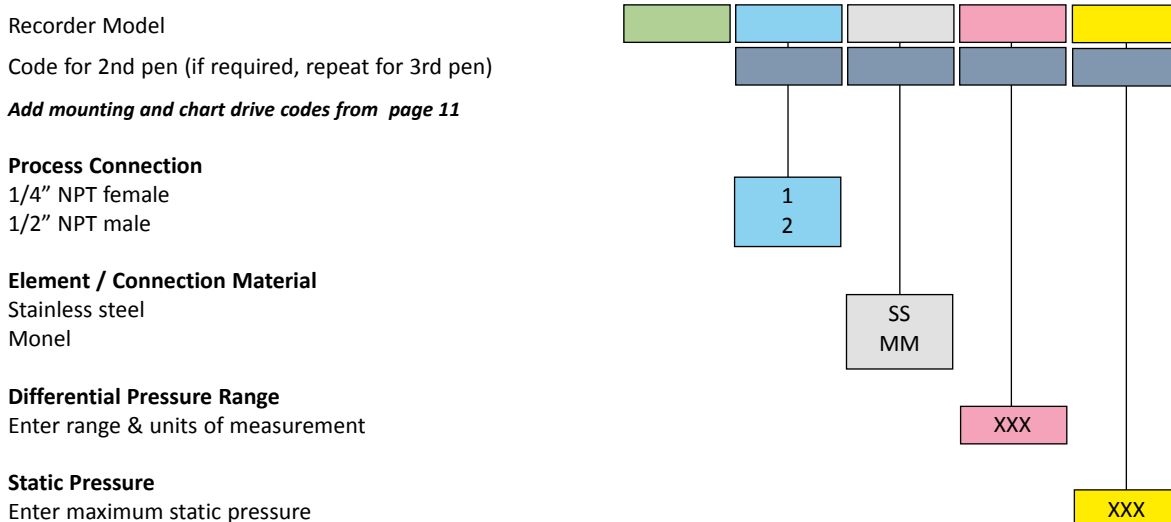

Clearscan C105 & M105 Pressure & Temperature Recorders

Choice of Cases

This range of temperature and pressure recorders can be built into either of two types of tough steel case. Both have a lockable front-hinged door, permitting easy access to the chart and pens, and may be either wall or panel mounted. C105's can be supplied complete with a portable stand.

The Clearscan M105 has a rectangular steel case, an aluminium door and triplex glass. Electrical and pneumatic, controller versions are available.

The C105 temperature and pressure recorders have a tough circular steel case which, is suitable for installing under severe industrial conditions. The door has a strong polycarbonate window.

Pens

The recorders utilise sealed ink capsules with built-in fibre-tipped pens which are replaced simply and without mess. Single pen recorders and the first pen of two pen recorders trace in red ink; the second pen of two pen recorders traces in green ink.

Charts and chart drives

The standard chart durations are one revolution every 12 hours, 24 hours or 7 days, the chart drive being either an electrical or a mechanical (clockwork) motor. Alternatively a 24 hour or a 7 day electrical chart drive with its own built-in, recharging reserve power unit, can be selected. This version gives a continuing trace through a mains failure. When running "normally" in the fully charged condition the power unit accumulator holds enough capacity to drive continuously for five days.

Standard Pressure Ranges

Standard Range	Sensing Element	Material
0.2 to 1 bar 0 to 1 bar 0 to 1.6 bar	Single Capsule	Beryllium Copper or Stainless steel
0 to 4 bar 0 to 6 bar 0 to 10 bar 0 to 16 bar 0 to 25 bar 0 to 40 bar	Bourdon Tube	Phosphor Bronze or Stainless Steel
0 to 60 bar 0 to 80 bar 0 to 100 bar 0 to 160 bar 0 to 250 bar 0 to 300 bar 0 to 400 bar 0 to 600 bar 0 to 1000 bar 0 to 1200 bar 0 to 1600 bar	Bourdon Tube	Stainless Steel
-1 to +1.5 bar -1 to +3 bar -1 to +5 bar -1 to +9 bar	Capsule	Phosphor Bronze or Stainless Steel
-1 to 0 bar	Bellows	Beryllium Copper

Other pressure ranges are available on request



C105 Chart Recorder



M105 Chart Recorder

Standard Temperature Ranges

Range	Range
-40 to +40 Deg C	0 to 160 Deg C
-30 to +30 Deg C	0 to 200 Deg C
-30 to +50 Deg C	0 to 300 Deg C
-25 to +25 Deg C	0 to 400 Deg C
0 to 40 Deg C	20 to 120 Deg C
0 to 50 Deg C	50 to 150 Deg C
0 to 60 Deg C	50 to 250 Deg C
0 to 100 Deg C	100 to 400 Deg C
0 to 120 Deg C	100 to 500 Deg C

Calibration in other units of pressure and temperature as well as non-standard ranges are available on request

Bulb Types

Type 301

This bulb type is used when no compression fitting is required. This bulb may be held in place by a bracket or clip (not supplied by Rototherm) or may be inserted directly into the process.

Type 302

This bulb has a compression gland fitting that slides along the capillary and is tightened into the required position. This bulb type is only available with plain stainless steel capillary (type C1) - armoured capillaries are not available as it is not possible to move the fitting along the armoured capillary. Bulb length cannot be specified.

Type 303

Compression gland fittings tighten on the bulb to provide liquid and gas tight seal. Once fitted the position of the gland fitting can only be altered by cutting off the olive and replacing it with a new one.

If required this bulb type may be specified with a compression gland fitting - in this instance please confirm the required overall length of the bulb.

See page 9 for bulb type illustrations

Specifications

Accuracy

±1% FSD

Chart Drive

Synchronous electric or mechanical spring wound. 12 hour, 24 hour or 7 day rotation - other rotations on request.

Inking System

Disposable fibre tipped pen.
Single pen : Red
2 pen : Red and green

Charts

255 mm diameter, circular chart

Case

C105: Steel body with foam moulded door and glass window. Polycarbonate doors are fitted as standard to recorders with pressure ranges above 60 Bar

M105: Steel body with aluminium and Triplex toughened glass door (polycarbonate glazing available as an option)

Power Supply

200 to 250 volts, 50Hz (60Hz available)
100 to 120 volts, 50Hz (60Hz available)

Pneumatic Control (M105 only)

Air Supply Pressure

1.4 bar (20 Psi)

Air Supply Pressure effect

No greater than 1% output change at 0.6 bar (9 Psi) per 5% change in supply pressure at 1.4 bar (20 Psi) at 100% proportional band.

Pneumatic Control Options

Control Option	Proportional Band	Integral Timer	Derivative Time
On/Off	Approximately 1% fixed	-	-
Proportional	1-50% and 4-200%	-	-
Proportional + Integral	1-50% and 4-200%	0.05 to 5 mins.	-
Proportional + Derivative	1-50% and 4-200%	-	0.05 to 5 mins.
Proportional + Integral + Derivative	1-50% and 4-200%	0.05 to 5 mins.	0.05 to 5 mins.

Output Pressure

0.2 to 1.0 Bar (3 to 15 Psi)

Air Connection Size

For 6.35 mm (1/4") outside diameter tubing

Air Supply & Output Gauges

0 to 2 Bar (0 to 30 Psi)

Air Consumption

Less than 3 litres/min at 0.6 bar output

Air Output Capacity

60 litres/min

Control Actions

Direct or reverse by simple positioning of nozzle/flapper

Mounting

Suitable for wall or panel mounting.
Portable option available (C105 only)

Instrument must be mounted vertically for accurate results.

Weight (approx.)

C105: 8.5 kg
M105: 14.0 kg

Approximate weight for recorder with 3 metres of capillary.

Dimensions

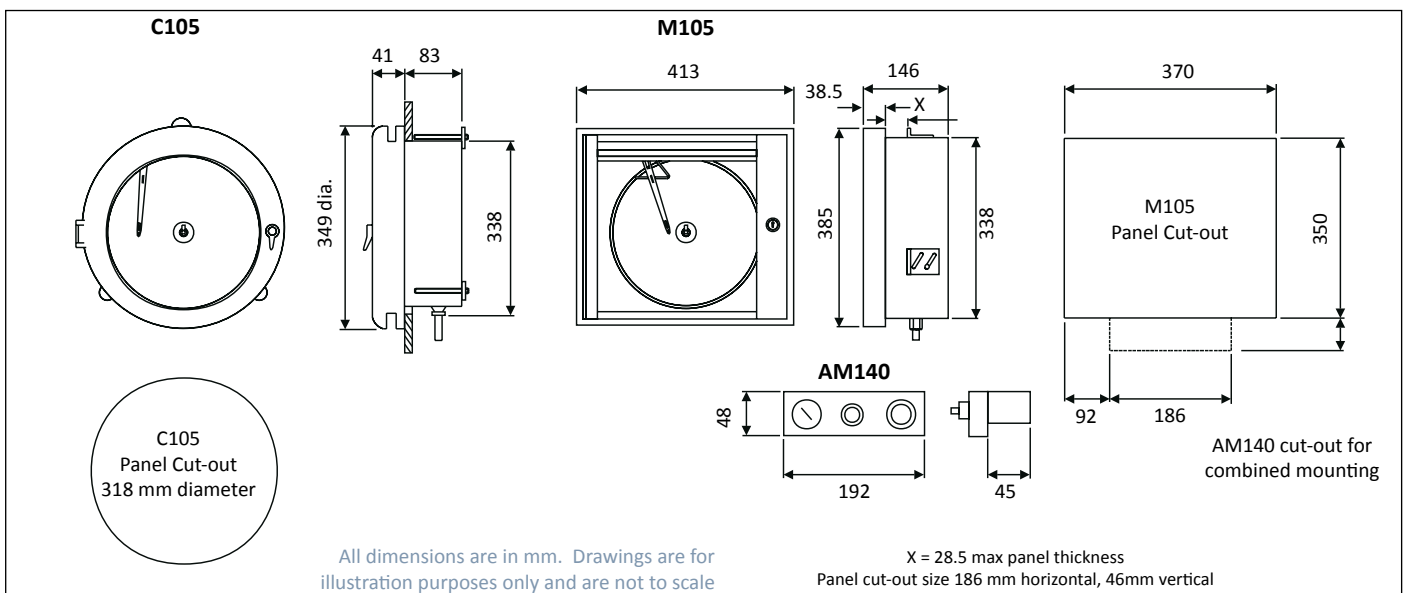

Ordering Codes - C105 & M105 Temperature Recorders

- C105 Temperature Recorder, Single Pen
- C105 Temperature Recorder, Two Pen
- M105 Temperature Recorder, Single Pen
- M105 Temperature Recorder, Two Pen
- Code for 2nd pen (if required)

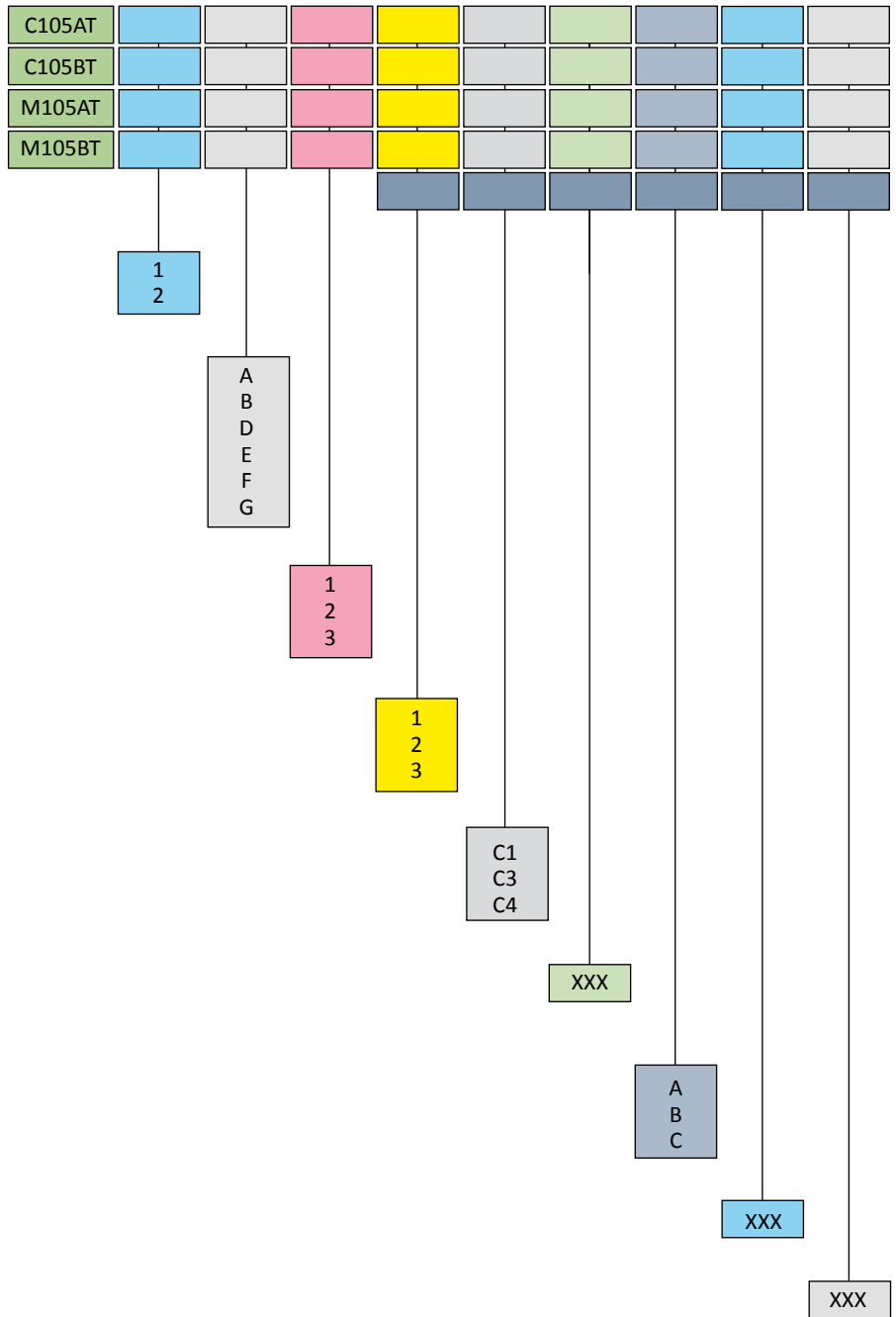

Mounting

- Wall / Panel
- Portable (C105 only)

Chart Drive

- Electric 240V 50Hz
- Electric 110V 50Hz
- Mechanical Spring Wound
- Battery Operated
- Electric 240V 50Hz with Battery Backup
- Other*

Chart Rotation

- 24 hour
- 7 day
- Other*

Bulb Options

- Type 301
- Type 302
- Type 303

Capillary Type

- Stainless steel
- Flexible stainless armour
- Flexible stainless armour over stainless

Capillary Length

- 3 metres
- Other (enter length in metres)

Fitting / Gland (type 302 or 303 bulbs only)

- No fitting required
- 1/2" BSP male
- Other

Bulb Immersion Length (Type 303 bulbs only)

- Enter length in mm

Temperature Range

- Enter range in °C or °F

**Notes:*

- a) When other is specified please add note to order code stating exact requirement.
- b) When specifying different ranges for 2 pen recorders, care should be taken to use compatible chart ranges. Details are available on request.
- c) For electrical control and alarms - please state exact requirement

Example Order Code

C105BT	1	A	1	3	C1	03	B	250	0-100	
					3	C1	06	B	250	0-200

Two pen temperature recorder, C105 case, wall mounted, electrical 240V 50Hz chart drive, 24 hour rotation.

Pen 1: 3 metres of C1 stainless steel capillary, type 303 bulb with a 1/2" BSP fitting, 250 mm immersion length, temperature range 0 to 100°C

Pen 2: 6 metres of C1 stainless steel capillary, type 303 bulb with a 1/2" BSP fitting, 250 mm immersion length, temperature range 0 to 200°C

Ordering Codes - C105 & M105 Pressure Recorders

- C105 Pressure Recorder, Single Pen
- C105 Pressure Recorder, Two Pen
- M105 Pressure Recorder, Single Pen
- M105 Pressure Recorder, Two Pen
- Code for 2nd pen (if required)

Mounting

- Wall / Panel
- Portable (C105 only)

Chart Drive

- Electric 240V 50Hz
- Electric 110V 50Hz
- Mechanical Spring Wound
- Battery Operated
- Electric 240V 50Hz with Battery Backup
- Other*

Chart Rotation

- 24 hour
- 7 day
- Other*

Process Connection

- Standard (3/8" BSP male)
- 1/2" BSP male
- Other

Element / Connection Material

- Non ferrous - Beryllium Copper, Phosphor Bronze
- Stainless steel
- Other

Pressure Range

Enter range and unit of measurement

Notes:

- a) When other is specified please add note to order code stating exact requirement.
- b) When specifying different ranges for 2 pen recorders, care should be taken to use compatible chart ranges.

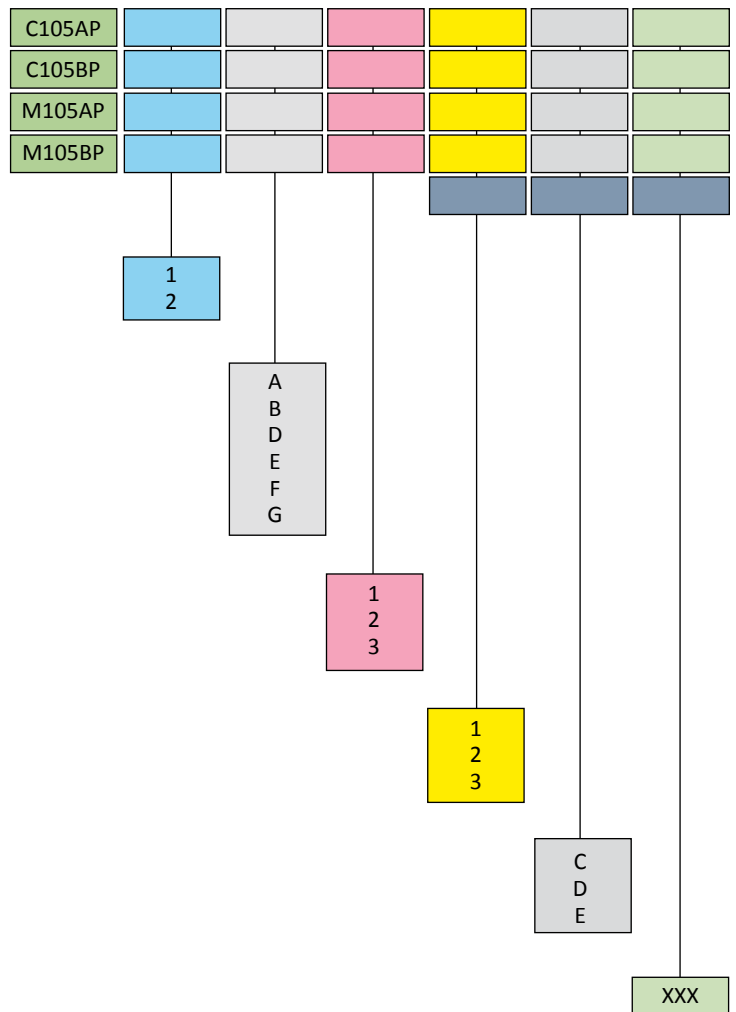

Example Order Code



Single Pen Pressure Recorder, C105 case, wall mounted, electrical 240 volt 50hz chart drive, 24 hour rotation, standard stainless steel 3/8" BSP connection, stainless steel element, range 0 to 10 Bar.

Pneumatic Control

Pneumatic control can be fitted to most recorders in the Clearscan M105 case. Providing a 0.2 to 1 bar (3 to 15 Psi) output signal for direct connection to control valves or other pneumatically driven regulators.

The pneumatic system operates on the motion balance principle, i.e. motion from the pneumatic feedback unit balances the motion from the pressure system. Control action occurs at or about the value set by the setting pointer. The pointer is adjustable over the full chart range and is fitted with a locking device to prevent accidental disturbance. Gauges displaying the supply and output pressures, and the control setting pointers, are clearly visible through the door of the recorder.

For more details, please contact Rototherm sales.

Pneumatic Control Options

The following options are available - Proportional only (P), Proportional + Integral (P + I), Proportional and Derivative (P + D) and Proportional + Integral + Derivative (P + I + D).

The instrument can be set to give either a reverse of direct acting output; reverse and direct action versions respectively provide a decreasing or increasing controller output pressure with a process pressure rise. Only one channel of pneumatic control would normally be fitted to single pen recorders and to the first pen of two pen recorders.

RPO & RTO Pressure & Temperature Recorders

- 1, 2 or 3 pen temperature & pressure recording and controlling at low cost
- Uses proven and reliable Rototherm pressure & filled system temperature systems
- Simple installation and maintenance requirement
- Portable stand or pipe mounting available
- Fully mechanical versions available
- Electrical, battery or mechanical chart drive options
- Electrical & Pneumatic control options

Introduction

These reliable and accurate instruments are suitable for most applications where there is a requirement for low cost temperature recording. Up to 3 pens can be fitted with three temperature systems or combination of temperature and pressure sensing systems.

Pens

Fitted to the pen arms are disposable fibre tipped pens which are readily replaced without mess.

Single pen recorders and the first pen of the two and three pen recorders trace in red ink, the second pen in blue, the third in green.

Charts and chart drives

The standard chart durations are one revolution every 12 hours, 24 hours or 7 days, the chart drive being either an electrical or a mechanical (clockwork) motor. Alternatively a 24 hour or a 7 day electrical chart drive with its own built-in, recharging reserve power unit, can be selected. This version gives a continuing trace through a mains failure.

Standard Pressure Ranges

Standard Range	Sensing Element	Material
0.2 to 1 bar 0 to 1 bar 0 to 1.6 bar	Single Capsule	Beryllium Copper or Stainless steel
0 to 4 bar 0 to 6 bar 0 to 10 bar 0 to 16 bar 0 to 25 bar 0 to 40 bar	Bourdon Tube	Phosphor Bronze or Stainless Steel
0 to 60 bar 0 to 100 bar 0 to 120 bar 0 to 160 bar 0 to 250 bar 0 to 300 bar 0 to 400 bar 0 to 600 bar 0 to 1000 bar 0 to 1200 bar 0 to 1600 bar	Bourdon Tube	Stainless Steel
-1 to +1.5 bar -1 to +3 bar -1 to +5 bar -1 to +9 bar	Capsule	Phosphor Bronze or Stainless Steel
-1 to 0 bar	Bellows	Beryllium Copper

Other pressure ranges are available on request

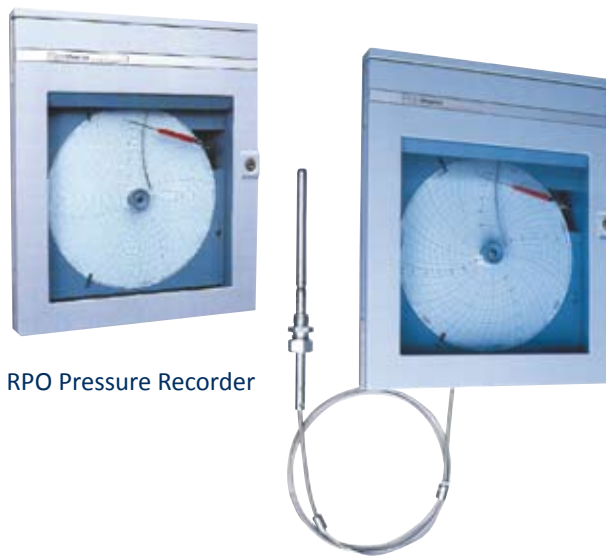

RPO Pressure Recorder

RTO Temperature Recorder

Standard Temperature Ranges

Range	Range
-40 to +40 Deg C	0 to 160 Deg C
-30 to +30 Deg C	0 to 200 Deg C
-30 to +50 Deg C	0 to 300 Deg C
-25 to +25 Deg C	0 to 400 Deg C
0 to 40 Deg C	20 to 120 Deg C
0 to 50 Deg C	50 to 150 Deg C
0 to 60 Deg C	50 to 250 Deg C
0 to 100 Deg C	100 to 400 Deg C
0 to 120 Deg C	100 to 500 Deg C

Calibration in other units of pressure and temperature as well as non-standard ranges are available on request

Bulb Types

Type 301

This bulb type is used when no compression fitting is required. This bulb may be held in place by a bracket or clip (not supplied by Rototherm) or may be inserted directly into the process.

Type 302

This bulb has a compression gland fitting that slides along the capillary and is tightened into the required position. This bulb type is only available with plain stainless steel capillary (type C1) - armoured capillaries are not available as it is not possible to move the fitting along the armoured capillary. Bulb length cannot be specified.

Type 303

Compression gland fittings tighten on the bulb to provide liquid and gas tight seal. Once fitted the position of the gland fitting can only be altered by cutting off the olive and replacing it with a new one.

If required this bulb type may be specified with a compression gland fitting - in this instance please confirm the required overall length of the bulb.

See page 9 for bulb type illustrations

Specifications

Accuracy

±1% FSD

Chart Drive

Synchronous electric or mechanical spring wound. 12 hour, 24 hour or 7 day rotation - other rotations on request.

Inking System

Disposable fibre tipped pens.

1 pen : Red

2 pen : Red and blue

3 pen : Red, blue and green

Charts

240 mm diameter, circular chart

Case

Glass filled polyester resin, protection rated to IP55.

Window

Acrylic

Power Supply

200 to 250 volts, 50Hz (60Hz available); 100 to 120 volts, 50Hz (60Hz available)

Battery operated chart drives require a 1.5 volt type "C" cell.

Electrical Alarm & Control

Contact rating (when fitted):

0.1A at 250V AC (non inductive)

0.01A at 250V DC (non-inductive)

Relay contact rating: 10A at 250V 50Hz

Contact adjustment range : 2% to 100%

Mounting

Suitable for surface or panel mounting. (Pipe mounting and portable options available)

Weight

Single pen : 6.5 kg (14.25lb)

Two pen : 7.0 kg (15.5lb)

Three pen : 7.5 kg (16.75lb)

The above weights include 3 metres of capillary. For each additional 3 metres add 0.25kg (0.5lb)

Specifications - RPO Pressure Recorder

Pressure System

Non ferrous or stainless steel bourdon tube for ranges 6 bar up to 1600 bar.

Non ferrous capsule and open stack system for lower ranges.

Process Connection

Standard: 3/8" BSP male, with nut and tail pipe or suitable for 6.35mm (1/4") outside diameter tube or 3/8" inside diameter tube.

Other process connections available include 1/4" BSP / NPT and 1/2" BSP / NPT

Receiver Type 1/4" BSP female (input 3-15 psi 0.2-1 bar)

Dimensions

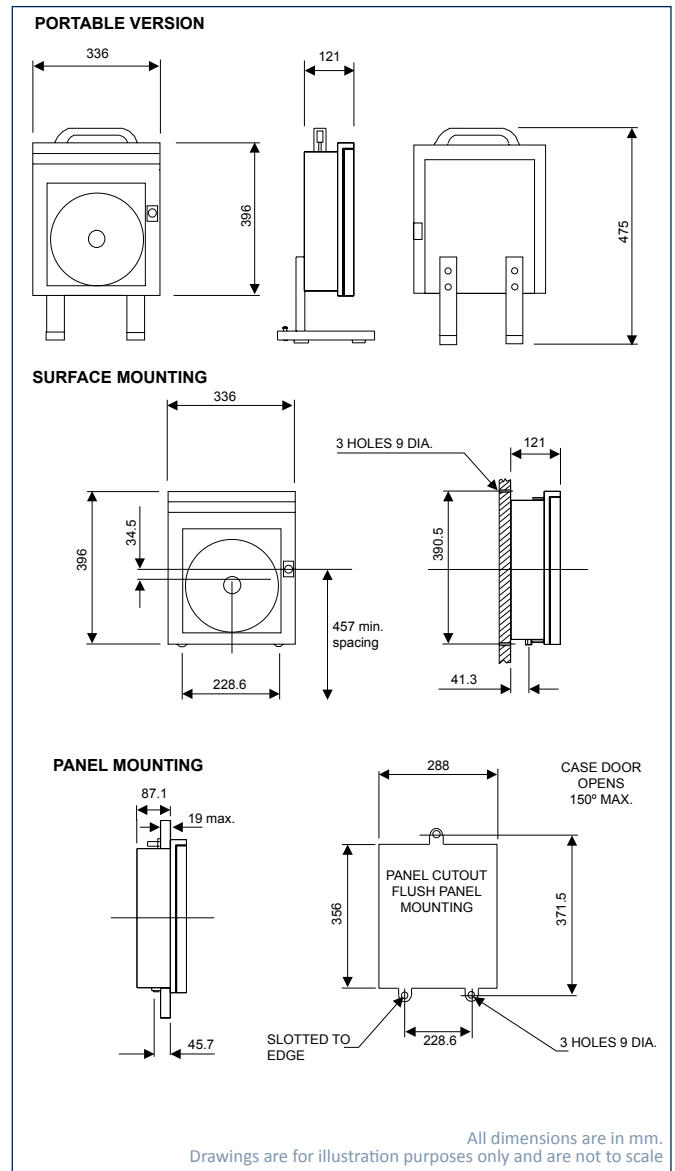

Specifications - RTO Temperature Recorder

Temperature System

Rototherm thermal bourdon tube temperature compensated.

Capillary

Microbore stainless steel tube with 3mm diameter stainless steel cover (type C1) as standard. Other capillary types are available.

Bulb and Stem

Stainless steel BS970 316. Standard diameter is 12.7mm.

Compression Fittings

Compression gland (adjustable). Stainless steel (1/2" BSP is standard). Other BSP, NPT and API are available on request. (suitable for pressures up to 3.5 bar)

Ordering Codes - RPO Pressure Recorders

RPO Pressure Recorder, Single Pen
 RPO Pressure Recorder, Two Pen
 RPO Pressure Recorder, Three Pen
 Code for 2nd pen (if required)
 Code for 3rd pen (if required)

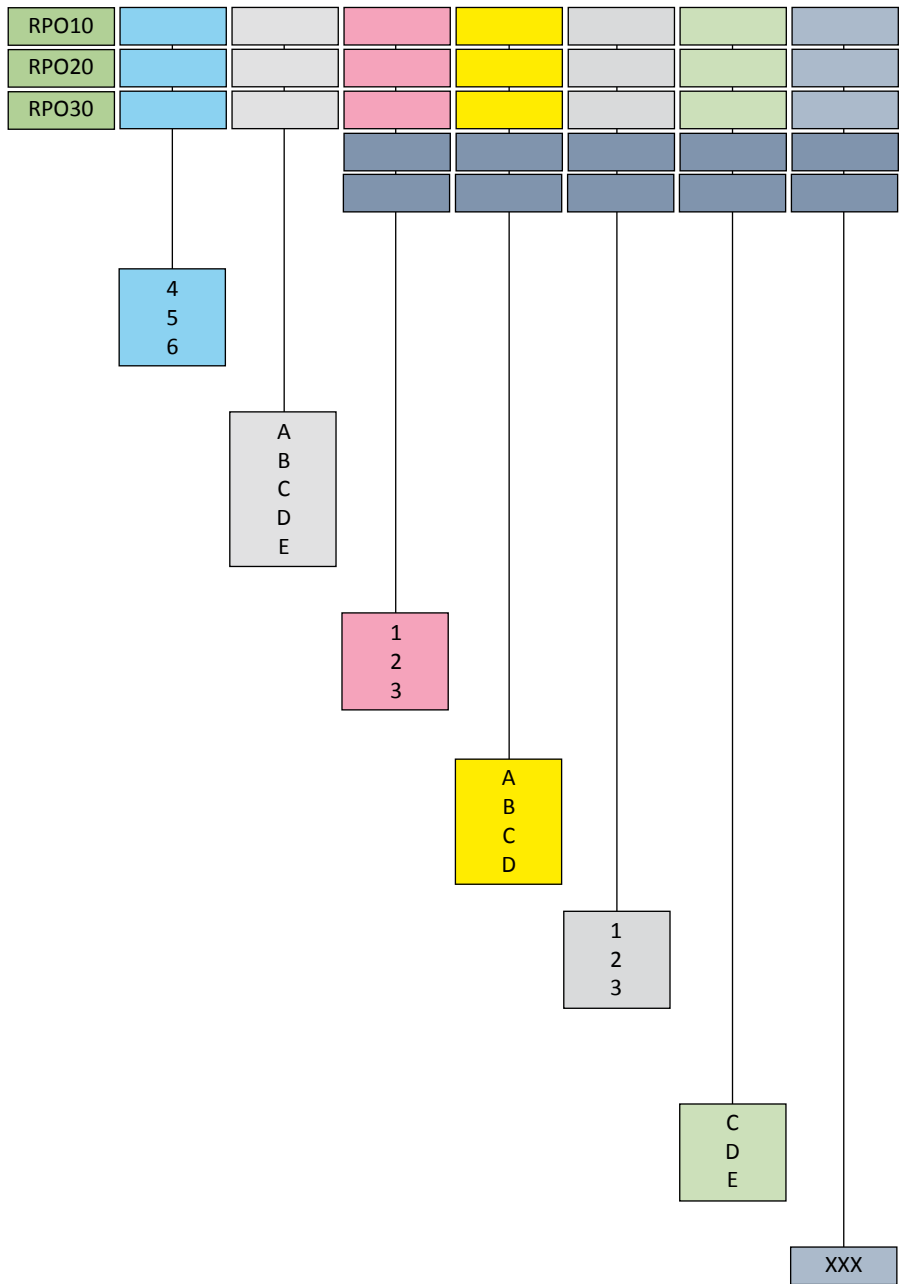

Mounting

Wall/Panel
 Portable
 Pipe

Chart Drive

Electric 240V 50Hz
 Electric 110V 50Hz
 Electric other*
 Spring Wound
 Battery

Chart Rotation

24 hour
 7 day
 Other*

Controls / Alarms

No control
 1st pen High & Low
 2nd pen High & Low
 1st & 2nd pen High & Low

Process Connection

Standard (3/8" BSP)
 1/2" BSP male
 1/2" NPT male
 Other

Element / Connection Material

Brass/Beryllium Copper/Phosphor Bronze
 Stainless Steel
 Other*

Range & Units of Measurement

Specify range & units

Notes

- (a) Where Other* is specified please add note to order code stating exact requirements
- (b) Should a combination of Pressure & Temperature be required please refer to the RTO temperature recorder order code.
- (c) When specifying different ranges for 2 or 3 pen recorders, care should be taken to use standard/compatible charts ranges.

Example Order Code



Single pen pressure recorder, wall mounted, electrical 240 volt 50Hz chart drive, 24 hour rotation, standard stainless steel connection, stainless steel element, range 0 to 10 bar.

Ordering Codes - RTO Temperature Recorders

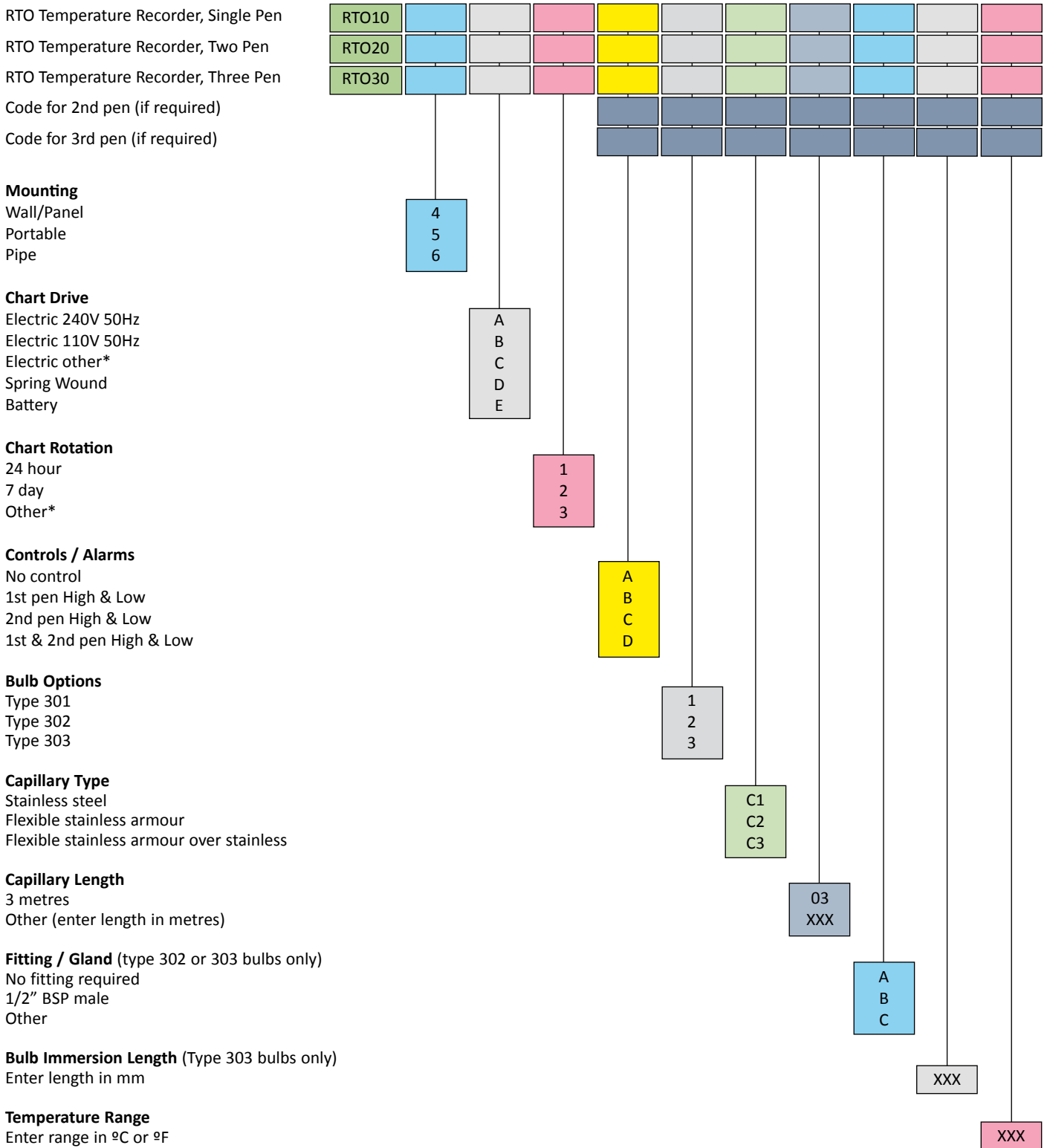

Example Order Code

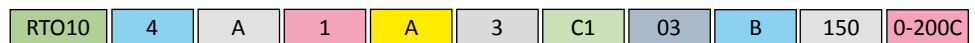

Single pen temperature recorder, wall mounted, electrical 240 volt 50hz chart drive, 24 hour rotation, no control, type 303 bulb, 3 metres of stainless steel capillary, 1/2" BSP male compression fitting, immersion length 150 mm, range 0 to 200 Deg C.

RTH Temperature & Humidity Recorders

- Temperature and/or humidity recording at low cost.
- Simple installation and maintenance requirement.
- Uses proven bimetallic coil and hygroscopic membrane for reliable results.
- Choice of ambient or remote sampling mode of recorder.
- Suitable for wall or flush panel mounting for easy installation.
- Portable stand available.

The RTH100 Series of temperature and humidity circular chart recorders uses the proven design combination of a bimetallic coil and a hygroscopic membrane for the direct measurement of temperature and humidity.

Changes in atmospheric temperature and humidity are detected by two elements within the recorder. The bimetallic coil monitoring the temperature and the hygroscopic element the humidity.

Air is drawn through the instrument and over the two sensing elements by an electrically driven fan. Expansion, or contraction, of the bimetallic coil, due to temperature change, causes pen movement by direct linkage. Similarly a change in humidity causes extension, or contraction, of the hygroscopic membrane and direct linkage causes the movement of the second pen.

Fitted to the pen are disposable fibre-tipped pens which are readily replaceable without mess. Each of the two pens traces in a different colour for ease of recognition.

Charts are supplied with the minimum values of the temperature and humidity at the centre. Standard chart durations are one revolution every 24 hours or 7 days with special durations available on request. Multi-speed chart drive, customer selectable, is available.

Each instrument can be supplied with either of two modes of sampling: the most commonly used ambient sampling mode, monitoring the atmosphere adjacent to the recorder; or remote sampling mode, where a continuous sample is extracted (e.g. through the wall of a room, or environmental chamber) and passed through the instrument. Options are available to return the sample to the environment from which it was extracted, or to the atmosphere surrounding the recorder.

Specifications

Range

Temperature: 0° to 40°C or 20° to 100°F
Humidity: 20 to 100% RH (see notes)

Measuring System

Temperature: Bi-metallic coil
Humidity: Hygroscopic membrane

Accuracy

Temperature: ±1% of the chart range
Humidity: ±2% within the limits 30 to 85% RH and 1° to 40°C

Chart

Diameter: 240 mm diameter

Chart Drive

Electrical motor
24 hour or 7 day rotation as standard 3 hour, 6 hour, 12 hour and 28 day on application



Photograph shows control option that is no longer available

Power Supplies

Voltage requirements: 110V or 230V 50/60 Hz
Power requirements: <20VA
Insulation, contact to earth: 2kV

Environmental Data

Storage temperature limits:
Temperature instruments: -10° to +50°C
Temperature/humidity inst.: 0° to 40°C

Storage humidity limits

Temperature instruments: 0 to 90%RH
Temperature/humidity inst.: 20 to 85% RH

Casing

Glass filled resin case with lockable hinged door with perspex window (polycarbonate to special order)

Weight

6.5 Kg approx.

Mounting

Ambient sampling: Wall or flush panel or portable*
Remote sampling: Wall

Note

When panel mounting, a suitable air circulation must be provided to the duct intake and the inlet and outlet ports must not be restricted.

* Free standing portable version available (ambient sampling type only)

Sampling Type

Total sampling line length is restricted to 1 metre max (20mm OD)

Notes

1. Where the temperature difference between sample air and case exceeds ±5°C then the sample line must be thermally insulated
2. Should the RH go above 85% RH it is possible that water droplets may form on the element. This may have a temporary or permanent affect on the calibration.

Models

RTH101A	Single Pen Ambient Humidity Recorder
RTH102A	Single Pen Ambient Temperature Recorder
RTH103A	Two Pen Ambient Temperature & Humidity Recorder

Dimensions

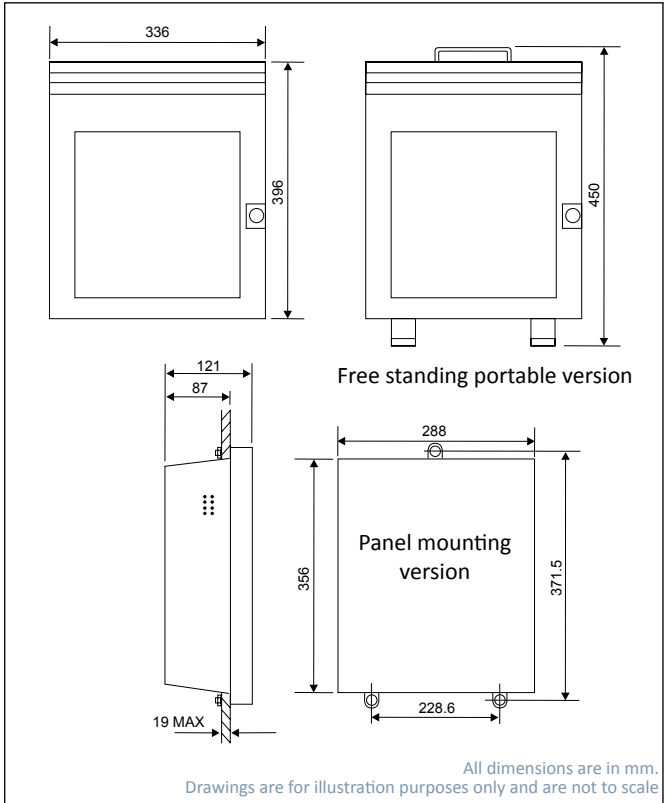

Ordering Codes - RTH Temperature & Humidity Recorders

- Single Pen Ambient Humidity Recorder
- Single Pen Ambient Temperature Recorder
- Two Pen Ambient Temperature & Humidity Recorder

Chart Rotation

- 3 hour
- 6 hour
- 12 hour
- 24 hour
- 7 day
- 28 day
- Multi-speed

Power Supply

- 110 Volts 50/60 Hz
- 230 Volts 50/60 Hz

Mounting

- Wall/Panel
- Portable

Sampling

- Ambient
- Remote
- Remote & re-entry

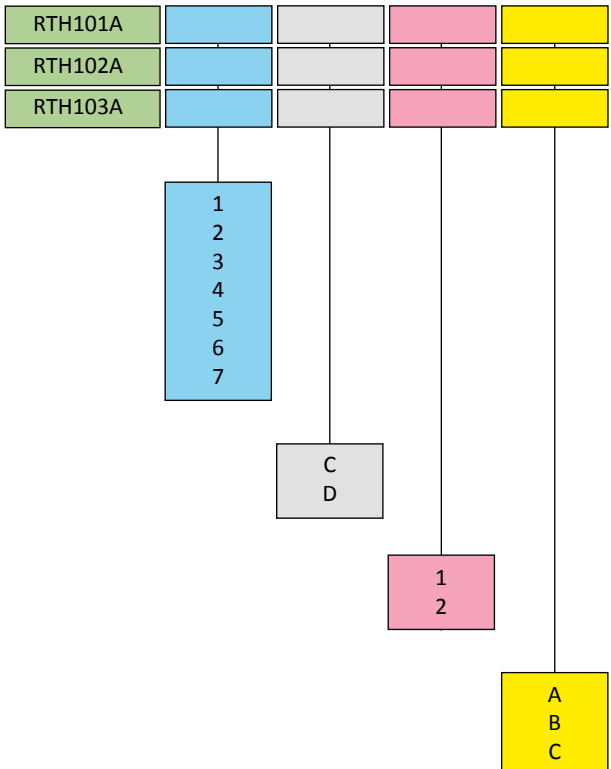

Example Order Code



Temperature and humidity recorder with 24 hour chart drive, 230V 50Hz supply, wall mounted with ambient measurement.

Pneumatic Recorder Controller Option



RTO and RPO model recorders are available with pneumatic control options.

These reliable and accurate instruments are suitable for most applications where there is a requirement for low cost recording and pneumatic control.

Up to two pens can be fitted with two pressure systems, two temperature systems or a combination of pressure and temperature (see recorder descriptions for further details).

Intrinsically Safe Applications

An all mechanical version is available for applications where no electrical supply is available or where an intrinsically safe instrument is required. Chart drive for this version uses a mechanical spring wound motor.

Control Options

Control can be specified to provide single term (P), two-term (P+I) or (P+D), three-term (P+I+D), on/off or differential gap control action for the control of temperature, gauge pressure, vacuum, differential pressure or absolute pressure. The two and three term controller generates all terms simultaneously. The proportional band, integral time and derivative time are adjustable over a wide range to enable accurate matching to plant conditions.

On/off instruments have a sensitivity adjustment equivalent to approximately 0.25 to 1% proportional band.

Differential gap instruments switch to maximum output at one switching point and minimum at the other switching point. The switching gap, which is spaced equally about the desired value index, is adjustable between 5% and 100% of the range.

Operation (Pneumatic Control - Type 9022)

Change of control action entails reversing a lever on the mechanism. It is not necessary to reposition the flapper/ nozzle assembly.

The movement of the measuring element actuates the “actual value” pen of the control mechanism which initiates a change in pneumatic output pressure. The output change is proportional to the deviation of the actual value pen and the desired value index.

The instrument incorporates a flapper/nozzle type of control mechanism: simple in operation, this unit gives reliable trouble free service over long periods without attention. A small amplifying relay which houses the restrictor for the nozzle air supply provides the necessary volume of air required by a control valve.

Specification

Air Supply

1.4 bar (20 psi)

Output

0.2 to 1 bar (3 to 15 psi) direct acting or 1 to 0.2 bar (15 to 3 psi) reverse acting.

Air Consumption

4.5 litres per minute max.

Proportional Band

3 to 300%

Integral Time

0.5 to 32 minutes

Derivative Time

0.25 to 12 minutes

Differential Gap

5 to 100%

On/Off Sensitivity

0.25 to 1%

Single Pen Controlling - (full pneumatic control available)

For single pen control the “type 9022” mechanism is utilised. This mechanism gives a wide proportional band of 3% to 300%, single, two or three term control.

Other options available with single pen control include on/off or differential gap control.

Automatic/Manual (AM)

AM panels are available to allow switching from Automatic to Manual if required.

IP600 & IT600 Indicating Pneumatic Controller

A pneumatic indicating controller which can be supplied to provide single-term (P), two-term (P + I or P + D), three-term (P + I + D), on/off or differential-gap control action for the control of temperature, gauge pressure, vacuum, differential pressure or absolute pressure.

The instrument incorporates a flapper/nozzle type of control mechanism: simple in operation, this unit gives reliable, trouble free service over long periods without attention. A small amplifying relay, which houses the restrictor for the nozzle air supply provides the necessary volume of air required by the control valve.

The two and three term controller generates all terms simultaneously. The proportional band, integral time and derivative time are adjustable over a wide range to enable accurate matching to plant conditions.

Specifications

Accuracy

±1% FSD

Ambient Temperature

-20 to +50°C

Air Supply

1.4 Bar (20 psig)

Output

0.2 to 1 bar (3 to 15 psi) direct acting or 1 to 0.2 Bar (15 to 3 psi) reverse acting

Air consumption

4.5 litres per minute max.

Proportional band

3 to 300%

Integral time

0.5 to 32 minutes

(Integral times down to approx. 5 seconds are obtainable by removing the capacity chamber.

Dimensions

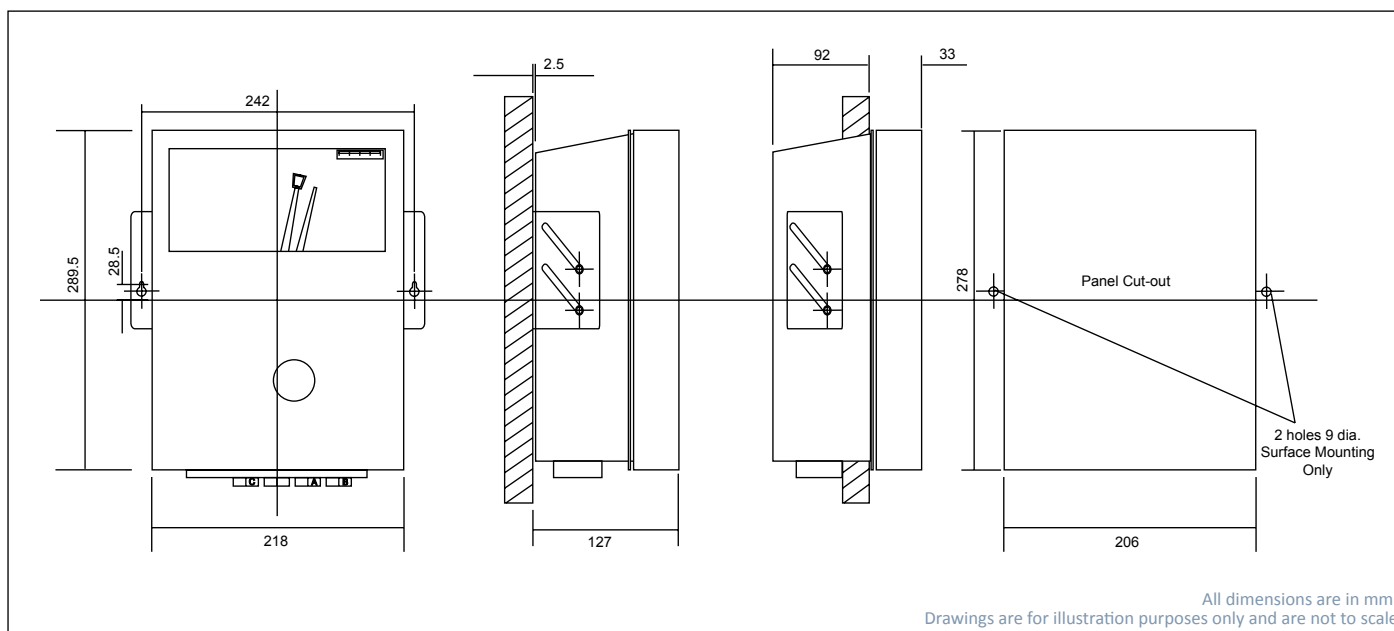

On/off instruments have a sensitivity adjustment equivalent to approximately 0.25 to 1% proportional band.

Differential gap instruments switch to a maximum output at one switching point and minimum at the other switching point. The switching gap, which is spaced equally about the desired value index, is adjustable between 5% and 100% of the range.

Change of control action entails reversing a lever on the mechanism. It is not necessary to remove the whole flapper/nozzle assembly.

Derivative time

0.25 to 12 minutes

Differential gap

5 to 100%

On/Off sensitivity

0.25 to 1%

Pneumatic connections

1/4" BSP female

Scale length

150 mm (6 inches)

Case

Glass filled polyester resin

Mounting

Suitable for surface or flush panel

Clearway M140 Indicating Pneumatic Controller

The Clearway M140 is a sophisticated pneumatic controller with robust mechanical sensing systems for temperature and pressure.

The controller operates on the motion balance principle, i.e. motion from the pneumatic feedback unit balances the motion from the process variable measuring element (bourdon tube systems for temperature and pressure, hygroscopic element for humidity).

The controller can be set for use with either direct or reverse acting pneumatic valves by changing the position of the nozzle-flapper assembly and feedback unit.

The controller works from an air supply pressure of 1.4 bar (20 psi) and provides air output signal pressures between 0.2 and 1 bar (3 and 15 psi).



Models - Temperature Controllers

Model	Control Action	Mounting
M140-111	On/Off	Wall
M140-181	Indicating Transmitter	Wall
M140-121	Proportional (or differential gap)	Wall
M140-131	Proportional + Integral	Wall
M140-141	Proportional + Derivative	Wall
M140-112	On/Off	Panel
M140-182	Indicating Transmitter	Panel
M140-122	Proportional (or differential gap)	Panel
M140-132	Proportional + Integral	Panel
M140-142	Proportional + Derivative	Panel

Standard Temperature Ranges

Range	Range
-20 to +50 Deg C	0 to 200 Deg C
-30 to +70 Deg C	0 to 300 Deg C
0 to 40 Deg C	0 to 400 Deg C
0 to 50 Deg C	20 to 120 Deg C
0 to 60 Deg C	50 to 150 Deg C
0 to 100 Deg C	50 to 250 Deg C
0 to 120 Deg C	100 to 400 Deg C
0 to 160 Deg C	100 to 500 Deg C

Standard Pressure Ranges

Range	Range
-1 to +1.5 bar	0 to 8 bar
-1 to +3 bar	0 to 10 bar
-1 to +5 bar	0 to 12 bar
-1 to +9 bar	0 to 16 bar
0.2 to 1 bar	0 to 20 bar
0 to 1 bar	0 to 25 bar
0 to 1.6 bar	0 to 30 bar
0 to 2.5 bar	0 to 40 bar
0 to 4 bar	
0 to 6 bar	0 to 1 bar vacuum

Calibration in other units of pressure and temperature as well as non-standard ranges are available on request

Models - Pressure Controllers

Model	Control Action	Mounting
M140-311	On/Off	Wall
M140-381	Indicating Transmitter	Wall
M140-321	Proportional (or differential gap)	Wall
M140-331	Proportional + Integral	Wall
M140-141	Proportional + Derivative	Wall
M140-312	On/Off	Panel
M140-382	Indicating Transmitter	Panel
M140-322	Proportional (or differential gap)	Panel
M140-332	Proportional + Integral	Panel
M140-342	Proportional + Derivative	Panel

Bulb Types

Type 301

This bulb type is used when no compression fitting is required. This bulb may be held in place by a bracket or clip (not supplied by Rotherm) or may be inserted directly into the process.

Type 302

This bulb has a compression gland fitting that slides along the capillary and is tightened into the required position. This bulb type is only available with plain stainless steel capillary (type C1) - armoured capillaries are not available as it is not possible to move the fitting along the armoured capillary. Bulb length cannot be specified.

Type 303

Compression gland fittings tighten on the bulb to provide liquid and gas tight seal. Once fitted the position of the gland fitting can only be altered by cutting off the olive and replacing it with a new one.

If required this bulb type may be specified with a compression gland fitting - in this instance please confirm the required overall length of the bulb.

See page 9 for bulb type illustrations

Specifications

Measuring Element

Temperature - fluid expansion, filled system
Pressure - phosphor bronze or stainless steel bourdon tube

Intrinsic Error of Indication

±1% of span

Ambient Temperature

-20°C to 55°C (temperature and pressure) 1°C to 40°C (RH)

Transmitter Accuracy

1% of indicated value.

Pressure Connection Size

3/8" BSP with nut and tail-piece for 8.0 mm (5/16") tubing.

Air Connection Size

For 6.4 mm (1/4") tubing, outside diameter

Air Supply Pressure

1.4 bar (20 psi)

Air Supply Effect

Not greater than 1% output change at 0.6 bar (9 psi) per 5% change in supply pressure at 1.4 bar (20 psi) at 100% proportional band.

Pointers

Red indicating, green setting

Output Gauge

0 to 2 bar (0 to 30 psi)

Output Pressure

0.2 to 1.0 bar (3 to 15 psi)

Air Consumption

Less than 3 litres/min. at 0.6 bar output (0.1 SCFM at 9 psi)

Air Output Capacity

60 litres/min. (2 SCFM) maximum.

Control Actions

Direct or reverse by simple positioning of nozzle flapper and feedback bellows.

Control Forms (Response)

On/off (approx. 1% of proportional band)

Proportional : Fully adjustable in two ranges: 1% to 50% and 4% to 200% (differential gap 5% to 100%).

Proportional + Integral : Integral action time 0.05 to 5 mins.

Proportional + Derivative : Derivative action time 0.05 to 5 mins.

Desired Value Setting (Set Point)

External knob in cover latch.

Case

Grey polyester resin-reinforced with glass fibre.

Cover

Clear acrylic - retained by external latch.

Dimensions

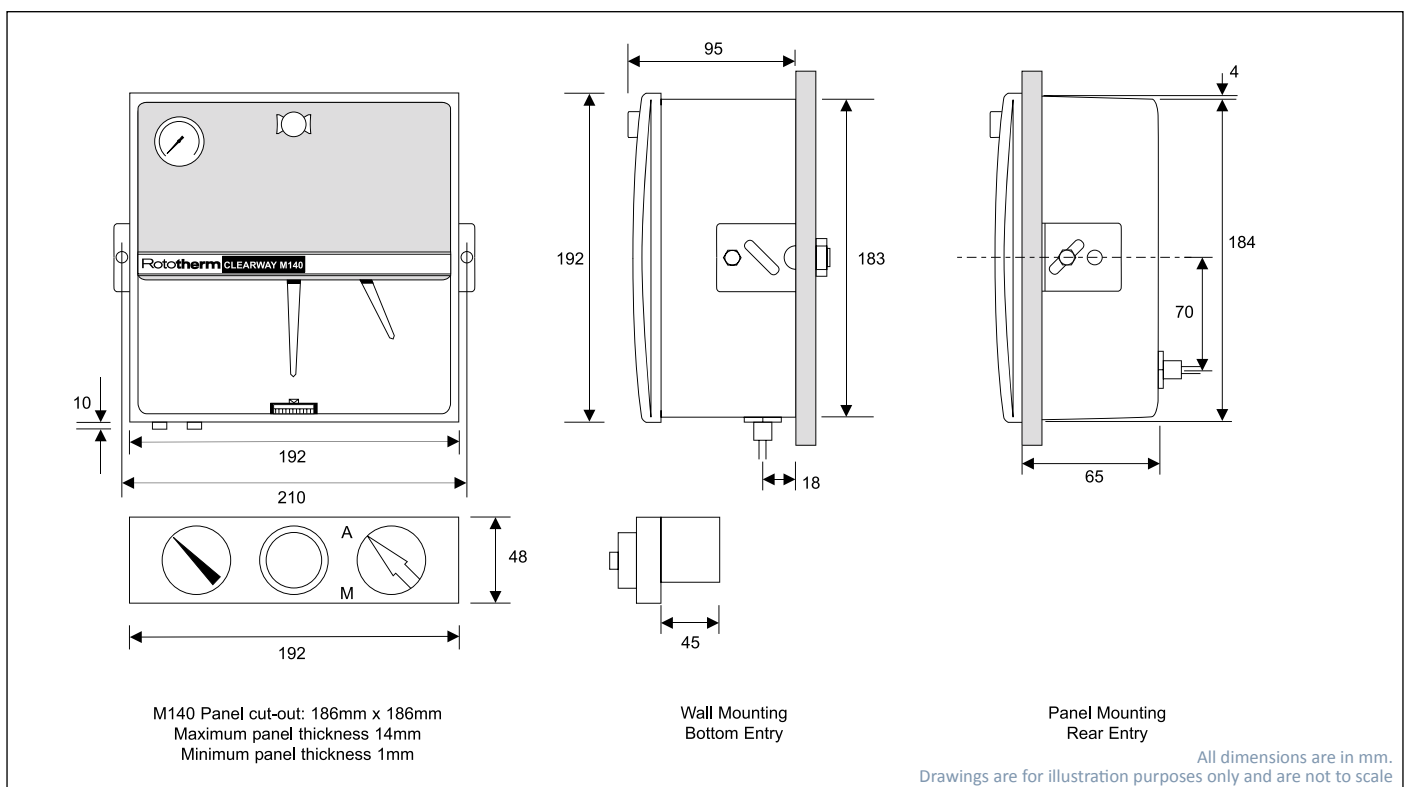

Thermometers Overview

- Rugged design & construction
- Accurate & reliable measuring systems
- Analogue and Digital versions available
- Wide choice of measuring ranges
- Electrical control options



Bimetallic Thermometers

Bimetallic thermometers are manufactured in various versions to suit most industrial applications. All bimetallic thermometers are manufactured with stainless steel cases and sensing stems and are used in many industries including food, beverage, dairy, pharmaceutical and petrochemical.

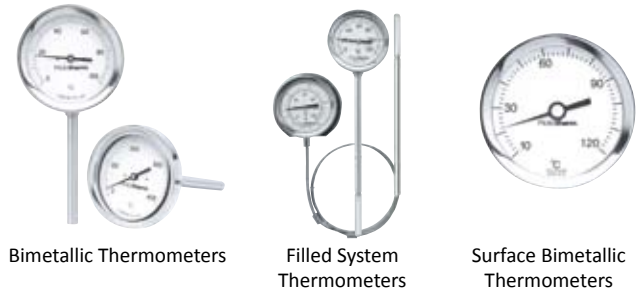

Filled System Thermometers

As well as bimetallic thermometers, Rototherm manufactures a wide range of filled system thermometers. Developed from the original Mercury in Steel thermometers, Rototherm now manufactures these thermometers with a safe, non-toxic filling. Both rigid stem and capillary models are available and these thermometers can be specified with electrical contact heads if required.

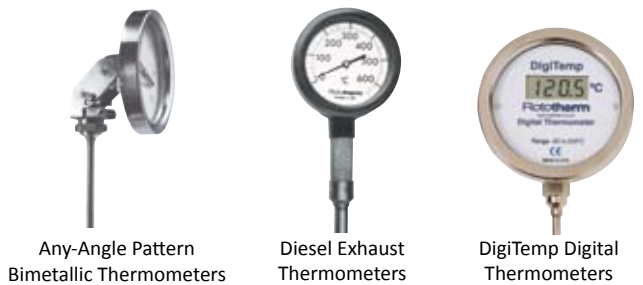

In addition to the range of filled system thermometers, Rototherm offers a range of thermometers for accurate and reliable indication of the exhaust gas temperature of diesel engines and generators.

The stem is fitted with a unique anti-resonant section which dampens out vibration of the instrument head, and eliminates the need for oil filling.

DigiTemp Digital Thermometers

The DigiTemp range of digital thermometers employ micro processors enabling extremely low power consumption to be achieved thus offering extend battery life. Available with either thermocouple or RTD PT1000 sensors, DigiTemp is offered in both rigid stem and remote reading versions.

The addition to the range of an ATEX approved intrinsically versions allows this product to be standardised in all pharmaceutical and petrochemical industries.

Thermowells

To complement our range of thermometers, Rototherm can offer an extensive range of thermowells to meet the exact requirements of your application.

Used predominantly in the power, process, pharmaceutical and petrochemical industries, thermowells are used to protect temperature indicators and sensors from process media and enable servicing or replacement of indicators without the need to shut down plant.

Available with either flanged or screwed process connections, Rototherm thermowells are available fabricated from tube, drilled from barstock or from forgings. Full material certification including original mill and suppliers material certificates can be provided. If required NACE standard MR-01-75 requirements can be met.

Thermometers - features

	Dial Sizes Available (mm)	Case Material	Capillary Version Available	Mechanical Actuation	Available with a Thermowell	Maximum Temperature Range (Deg C)	Electrical Contacts Available
Light Duty Bimetallic Thermometers	63	Stainless Steel	⊗	●	○	400	⊗
Heavy Duty Bimetallic Thermometers	63 100 160	Stainless Steel	⊗	●	○	550	○
Any Angle Pattern Bimetallic Thermometers	100 130 160	Stainless Steel	⊗	●	○	550	○
Surface Bimetallic Thermometers	63	Stainless Steel	⊗	●	⊗	400	⊗
Filled System Thermometers	100 160	Stainless Steel	○	●	○	650	○
Diesel Exhaust Thermometers	100	Polyester Resin	○	●	○	650	○
DigiTemp Digital Thermometers	100	Stainless Steel	○	⊗	○	800	⊗

● = standard ○ = option ⊗ = not available

please refer to product pages in this catalogue for full product specifications

Pressure Gauges Overview

- Rugged design & construction
- Choice of case styles and mountings
- Analogue and Digital versions available

- Wide choice of measuring ranges
- Electrical control options



With the acquisition of the pressure gauge manufacturer Sydney Smith Dennis (SSD) in 1998, Rototherm's range of pressure gauges dramatically increased to include gauges to suit most industrial applications.

Process Gauges

A wide range of process gauges are offered including stainless steel cased Elite safety pattern gauges and high corrosion resistant DMC cased pressure gauges. Low range capsule gauges are also offered.

Differential Pressure Gauges

Rototherm manufactures a range of high quality, cost effective and reliable differential pressure gauges designed to measure the difference in pressure between two points in a system and show it on a single dial gauge such as differential pressure across an orifice plate.

Digital Pressure Gauges

DigiGauge Digital Pressure Gauges offer high accuracy and a 4 digit display - which enables it to be used as a digital standard test gauge. The DigiGauge has been designed to cover a wide range of test and measurement applications with pressure ranges from vacuum to 400 bar.

DigiGauge is offered with the option of a 4 to 20mA retransmission signal and may be specified with maximum and minimum value display. The addition to the range of intrinsically safe versions allows DigiGauge to be used in hazardous areas

Pressure Transmitters

The Rototherm range of Pressure Transmitters provide a 4 to 20 mA output signal by utilising a diaphragm strain gauge mounted with an amplifier in a stainless steel housing. These reliable instruments are rugged and easy to install.



SPG Elite Safety Pattern Pressure



RPG Process Gauges



DMC Cased Safety Pattern Gauges



SPGA Aluminium Cased Safety Pattern Gauges



Gauges fitted with Diaphragm Seal Units



PTX Pressure Transmitters



Turret Style Safety Pattern Gauges



DigiGauge Digital Pressure Gauges



Differential Pressure Gauges

Pressure Gauges - features

		Dial Sizes Available (mm)	Case Material	Wetted Parts	NACE MR-01-75 Option	Glycerine Filling Option	Diaphragm Seal Option	Electrical Contact Option
SPG	Safety Pattern Pressure Gauge	100 150	SS	SS M	○	○	○	○
RPG	Process Pressure Gauge	63 100 150	SS	SS M	○	○	○	○
RCG	Capsule Pressure Gauge	100 150	SS	BB SS	⊗	⊗	⊗	⊗
DMC	Safety Pattern Pressure Gauge	100 150	DMC	SS M	○	○	○	○
SPGA	Safety Pattern Pressure Gauge	63 100 150 200 250 300	AL	BB SS	⊗	⊗	○	⊗
TURRET	Safety Pattern Pressure Gauge	115	Phen	SS M	○	○	○	⊗
DG1	DigiGauge Digital Pressure Gauge	100	SS	SS	⊗	⊗	○	⊗
DPG	Differential Pressure Gauges	50 63 80 100 112 115 150	SS	AL BB SS M	○	○	○	○
TPG	Test Pressure Gauges	150 200 250 300	AL SS DMC	BB SS	⊗	⊗	⊗	⊗

○ = option ⊗ = not available AL = Aluminium BB = Non Ferrous DMC = Dough Moulded Compound M = Monel Phen = Phenolic SS = Stainless Steel

please refer to product data sheets and catalogues for full product specifications

Temperature Assemblies Overview

The Rototherm / Thermocouple range of temperature assemblies has been designed for all industrial applications and is manufactured in strict accordance with the companies ISO 9001:2000 Quality System.

The range includes probes suitable for direct insertion into processes without protective thermowells and full assemblies complete with screwed or flanged thermowells and connection heads.

Connection Heads

Our comprehensive range of connection heads provides the best environmental protection for the electrical terminals on terminal blocks or temperature transmitters fitted to resistance thermometers or thermocouple inserts.

Temperature Transmitters

Temperature transmitters are used to convert the primary sensing signal, usually a resistance change for RTD sensors or EMF for thermocouples, into a standard current signal of 4-20mA. We offer a comprehensive range of temperature transmitters suitable for thermocouples or platinum resistance thermometers (RTD), these transmitters may be either head or rack mounted. Temperature ranges may be factory set or user adjusted. (Programmable, intrinsically safe, Hart®, Profibus® and Foundation Fieldbus® communication versions are available).

Mineral Insulated Thermocouples

A Thermocouple consists of two electrical conductors of dissimilar material connected at one end (the hot junction), the two free ends are connected to the measuring instrument via a reference junction (the cold junction). The connection of these two materials provides an electromotive force (emf).

Mineral Insulated Resistance Thermometers

A Resistance Thermometer is a temperature sensor constructed from resistance wire wound into an element. It is used to measure temperature by means of a change in the electrical resistance with a rise or fall in temperature. The most popular wire used in Resistance Thermometers is platinum, although nickel or copper can also be used.

Lagging Extensions

Lagging extensions are available in a wide range of lengths, sizes and fittings. Materials include Carbon Steel and Stainless Steel. They allow the connection head to be positioned away from the heat source, or through insulating lagging. Nipple/Union/Nipple and Breakaway couplings allow rapid disconnection for testing, and orientation.

Thermowells

Thermowells are used extensively in the power, process, pharmaceutical and petrochemical industries. They are used to protect temperature indicators and sensors from process media and enable servicing or replacement of sensors without the need to shut down plant.

Rototherm thermowells are precision made to the highest standards of finish in our modern well equipped machine shop and are manufactured to Rototherm's high quality standards approved to BS EN ISO 9001.

Thermowells are available fabricated from tube or drilled from barstock or forgings, full material certification, including original mill and suppliers materials certificates can be provided. If required NACE standard MR-01-75 requirements can be met.

Our custom-design ability puts us ahead of the competition for providing thermowells. As part of an assembly or as a replacement, we can provide thermowells of any size, material and specification. As part of our solution we can also offer stress and frequency calculations to ensure you have the correct design for the job.



Cast Iron H70 Head Standard Lid Cast Iron H70 Head Glass Window



Model KNY Connection Head



Model TR48 Temperature Transmitter



Model TR12 Digital Temperature Transmitter



Flow Products Overview

Accurate and reliable flow measurement equipment is essential for all types of industry processes all over the world. Whatever your process requirement for flow measurement, be it water, oil and gas, air, steam, waste water or other fluid, we have the answer, combined with the added flexibility of designing and manufacturing a system to suit your requirements.

Our vast knowledge and experience of providing solutions for organisations worldwide has proven our capability to provide the complete range of flow measurement equipment.

Our custom-designed measurement solutions are typically of the differential pressure type, including orifice plates, Venturi tubes, Pitot tubes and flow nozzles.

Orifice Plates

The most common and widely used differential pressure producers, suitable for a wide range of flow measurement applications in line sizes of 50 mm and above. Choose 'concentric square edged' for general application, 'conical entrance' or 'quarter circle' for low Reynolds number flows, and 'segmental' or 'eccentric' for flows containing light solids and slurries.

Based on proven technology, orifice plates have no moving parts and are suitable for high temperature and pressure applications. Orifice plates are recommended for clean liquids, gases and low velocity steam flows.

Restriction orifice plates can be used as a simple pressure reducing device, or to limit flow rate in a pipeline. They are designed to slip between pipe flanges.

Flow Nozzles

For measurements where high temperatures and velocities are present, the flow nozzle may provide a better solution than an orifice plate. Its construction makes it substantially more rigid in these adverse conditions and flow coefficient data at high Reynolds numbers is better documented than for orifice plates. The inlet is contoured, and may be either radius entrance (ISA1932) or elliptical entrance (ASME long radius). The flow nozzle has about a 65% greater flow capacity than an orifice with the same diameter.

Venturi Tubes

There are two common types of Venturi tube - the Venturi nozzle, and the classical Venturi. Both feature a convergent inlet section and a divergent outlet section. The major advantage of the Venturi over orifice plates and flow nozzles is in the area of pressure recovery. Typically, unrecovered pressure is in the region of 10 - 30% of measured DP as opposed to 40 - 90% for an orifice plate (depending on beta ratio). Although the cost of a Venturi can be comparatively high, where pumping costs are important the initial outlay can be justified.

Differential Pressure Gauges

Rototherm manufactures a range of high quality, cost effective and reliable differential pressure gauges designed to measure the difference in pressure between two points in a system and show it on a single dial gauge such as differential pressure across an orifice plate.

Flow Recorders

Utilising a high quality differential pressure unit, the Clearscan range of circular chart recorders includes options for measuring temperature and pressure as well as flow.



RTJ Type Orifice Plate



Orifice Flange Assembly

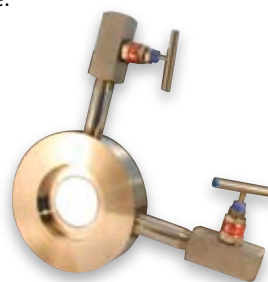

Orifice Carrier & Integral Plate
(show with optional isolation valves)



Restriction Orifice Plate



Differential Pressure Gauges